

Hydraulic dampers from ACE are maintenance-free, self-contained and sealed units. They are available with body diameters from 12 mm up to 70 mm and with stroke lengths of up to 800 mm. As standard they are supplied as double acting dampers but a single acting version is also available. The single acting version is controllable in one direction only, with free flow in the opposite direction. The travel speed is adjustable and remains constant throughout the stroke. **The new adjustment segment on the piston makes sensitive speed adjustment easy.** ACE's hydraulic dampers sport the sleek design of our gas springs. **The coated body and the piston rod with a special wear-resistant coating provide an exceptionally long lifetime and excellent corrosion protection.** A wide range of screw on mounting accessories make them very versatile and easy to install. Typical applications include machine guards and lids, fire safety flaps and doors, damping oscillations of suspended loads (Power and Free Systems) etc.

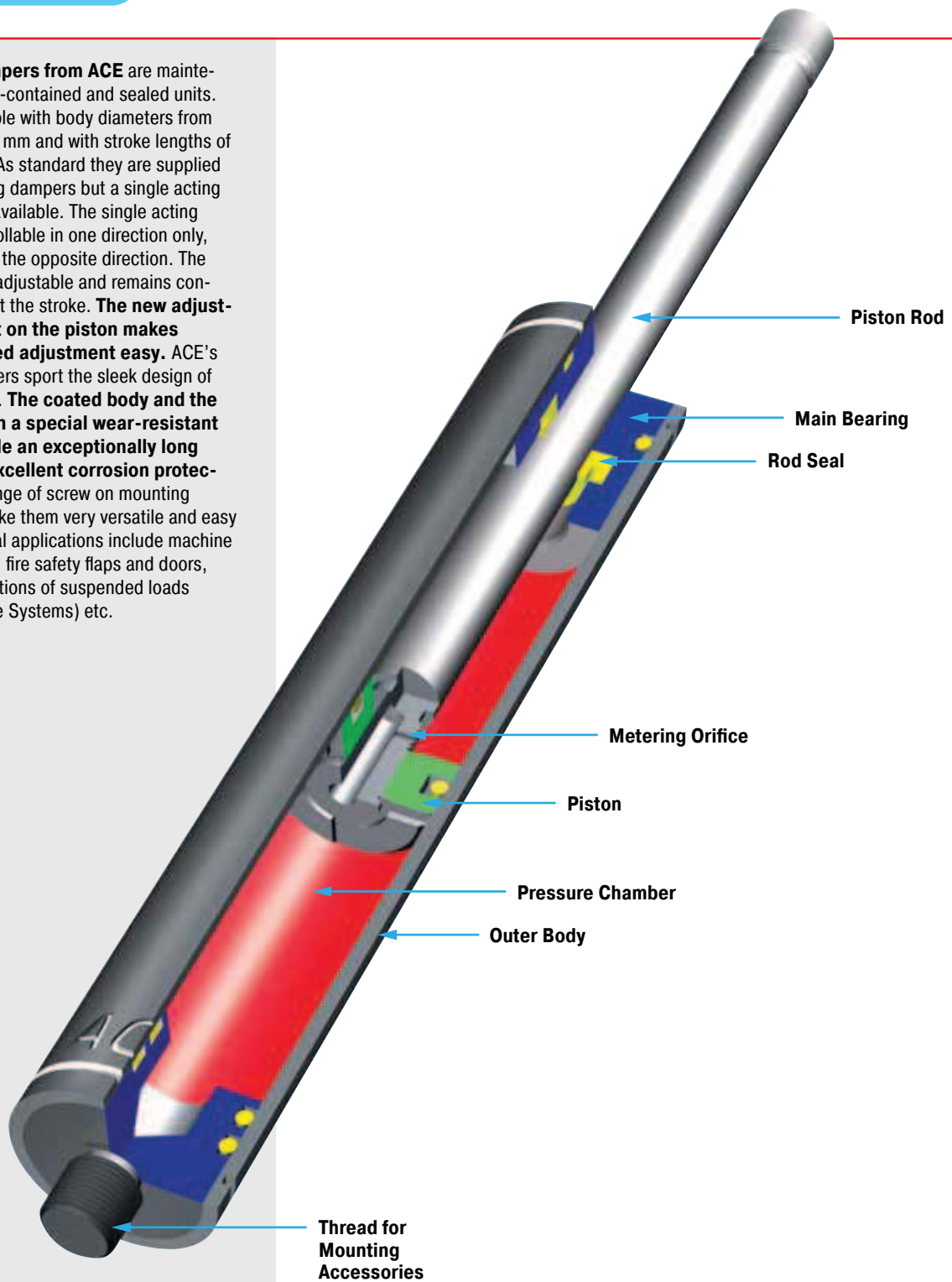

Function: The stepless adjustment of the damping rate is achieved by pulling (or pushing) the piston rod to its fully extended (or compressed) position and then turning the piston rod.

Operating fluid: Hydraulic oil

Mounting: In any position. End fittings must be positively secured to prevent unscrewing.

Operating temperature range: -20 °C to 80 °C

On request: Special lengths, alternative seals and end fittings.



End Fitting

Standard Dimensions

End Fitting

A3,5

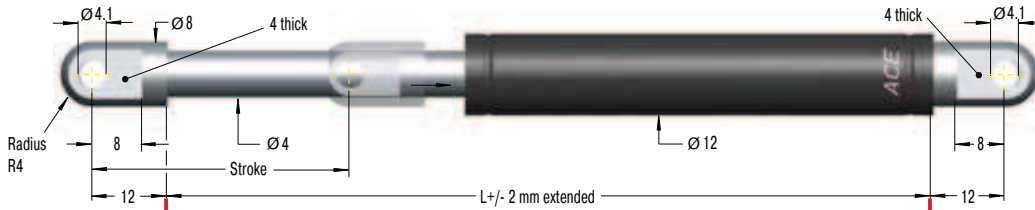

Eye A3,5
max. force 370 N

B3,5



Stud Thread B3,5

C3,5

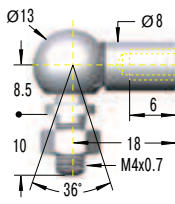

Angle Ball Joint C3,5
max. force 370 N

D3,5

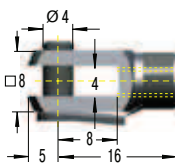

Clevis Fork D3,5
max. force 370 N

E3,5

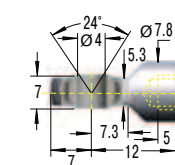

Swivel Eye E3,5
max. force 370 N

G3,5

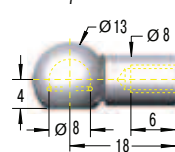

Ball Socket G3,5
max. force 370 N

Dimensions

| Type | Stroke mm | L extended | 1 Max. Compression Force N |
|----------|-----------|------------|----------------------------|
| HB-12-10 | 10 | 55 | 180 |
| HB-12-20 | 20 | 75 | 180 |
| HB-12-30 | 30 | 95 | 180 |
| HB-12-40 | 40 | 115 | 180 |
| HB-12-50 | 50 | 135 | 180 |
| HB-12-60 | 60 | 155 | 180 |
| HB-12-70 | 70 | 175 | 180 |
| HB-12-80 | 80 | 195 | 150 |

¹ Max. extension force for all stroke lengths 180 N.

Ordering Example

HB-12-30-AC-M
 Type (Hydraulic Damper) _____
 Body Ø (12 mm) _____
 Stroke (30 mm) _____
 Piston Rod End Fitting A3,5 _____
 Body End Fitting C3,5 _____
 Damping Direction (M = out stroke only) _____

Damping Options

- P = Damping in both directions
- N = Damping on in stroke only
- M = Damping on out stroke only
- X = Special model suffix

The end fittings are interchangeable and must be positively secured by the customer to prevent unscrewing (i.e. Loctite). For mounting accessories see page 185.

Rod Shroud W3,5-12

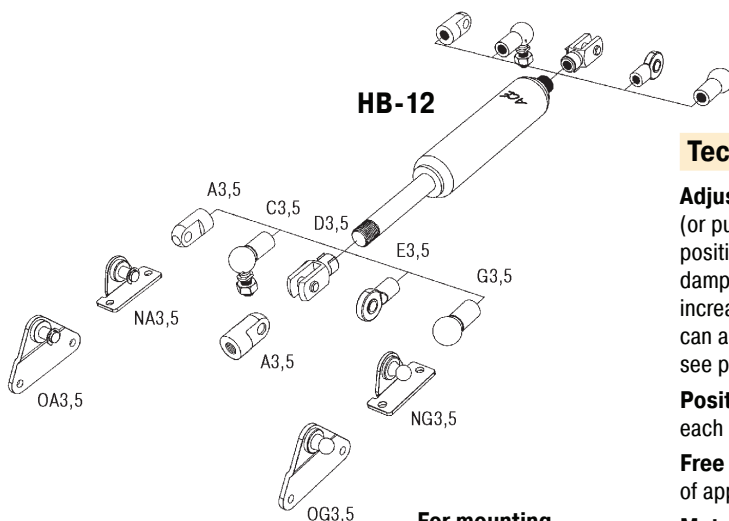
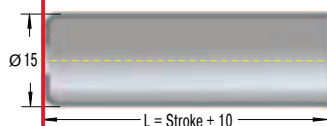

For mounting accessories see page 185.

Technical Data

Adjustment: Adjustment of the damping rate is achieved by pulling (or pushing) the piston rod to its fully extended (or compressed) position. Whilst still pulling the piston rod turn it clockwise to increase damping and anti-clockwise to decrease damping. If the resistance increases noticeably, stop adjusting to avoid damage. The adjustment can add a max. of 6 mm to the L dim. shown (adjustment instruction see page 145).

Positive stop: Provide mechanical stops 1 to 1.5 mm before end of each stroke direction.

Free travel: Construction of standard damper results in a free travel of approx. 21 % of stroke.

Material: Body: Black coated steel. Piston rod: Stainless steel (1.4305). End fittings: Zinc plated steel.

Separator piston: Available as a special option to remove free travel. Also provides extension force of min. 20 N. Dimension: L = 2.6 x stroke + 41 mm. Part number: Add suffix -T.

End Fitting

Standard Dimensions

End Fitting

| Dimensions | | | |
|------------|-----------|------------|----------------------------|
| Type | Stroke mm | L extended | 1 Max. Compression Force N |
| HB-15-25 | 25 | 93 | 800 |
| HB-15-50 | 50 | 143 | 800 |
| HB-15-75 | 75 | 193 | 800 |
| HB-15-100 | 100 | 243 | 350 |
| HB-15-150 | 150 | 343 | 300 |

1 Max. extension force for all stroke lengths 800 N.

Ordering Example
HB-15-150-CC-M
 Type (Hydraulic Damper) _____
 Body Ø (15.6 mm) _____
 Stroke (150 mm) _____
 Piston Rod End Fitting C5 _____
 Body End Fitting C5 _____
 Damping Direction (M = out stroke only) _____

Damping Options
 P = Damping in both directions
 N = Damping on in stroke only
 M = Damping on out stroke only
 X = Special model suffix

The end fittings are interchangeable and must be positively secured by the customer to prevent unscrewing (i.e. Loctite). For mounting accessories see page 185.

End Fitting Details:
A5 Eye max. force 800 N
B5 Stud Thread
C5 Angle Ball Joint max. force 500 N
D5 Clevis Fork max. force 800 N
E5 Swivel Eye max. force 800 N
G5 Ball Socket max. force 500 N
W5-15 Rod Shroud L = Stroke + 20

For mounting accessories see page 185.

Technical Data

On request: Special lengths, alternative seals and end fittings.

Mounting: In any position. End fittings must be positively secured to prevent unscrewing.

Adjustment: Adjustment of the damping rate is achieved by pulling (or pushing) the piston rod to its fully extended (or compressed) position. Whilst still pulling the piston rod turn it clockwise to increase damping and anti-clockwise to decrease damping. If the resistance increases noticeably, stop adjusting to avoid damage. The adjustment can add a max. of 6 mm to the L dim. shown (adjustment instruction see page 145).

Positive stop: Provide mechanical stops 1 to 1.5 mm before end of each stroke direction.

Free travel: Construction of standard damper results in a free travel of approx. 20 % of stroke.

Material: Body: Black coated steel. Piston rod: With wear-resistant coating. End fittings: Zinc plated steel.

Separator piston: Available as a special option to remove free travel. Also provides extension force of min. 40 N. Dimension: L = 2.45 x stroke + 47 mm. Part number: Add suffix -T.

End Fitting

Standard Dimensions

End Fitting

A8 Eye **A8**
max. force 3000 N

B8 Stud Thread **B8**

C8 Angle Ball Joint **C8**
max. force 1200 N

D8 Clevis Fork **D8**
max. force 3000 N

E8 Swivel Eye **E8**
max. force 3000 N

G8 Ball Socket **G8**
max. force 1200 N

Rod Shroud W8-22

Dimensions: $\varnothing 8.1$, $\varnothing 14$, 10 thick, Radius R7, 14, Stroke, $\varnothing 8$, $\varnothing 23$, 10 thick, $\varnothing 8.1$, 14, 20, L +/- 2 mm extended + max 6 mm for adjustment setting, 20, 8, 9, $M8 \times 1.25$, $\varnothing 20$, $\varnothing 13$, 12, 15, 16.5, 30, $M8 \times 1.25$, 36°, $\varnothing 8$, 16, 8, 10, 16, 32, 24°, $\varnothing 8$, 6, 13, 36, 16, 8, 12, 13, 36, 16, $\varnothing 20$, $\varnothing 13$, 6, 13, 30, $\varnothing 28$, L = Stroke + 30

| Dimensions | | | |
|------------|-----------|------------|----------------------------|
| Type | Stroke mm | L extended | 1 Max. Compression Force N |
| HB-22-50 | 50 | 153 | 1 800 |
| HB-22-100 | 100 | 253 | 1 800 |
| HB-22-150 | 150 | 353 | 1 800 |
| HB-22-200 | 200 | 453 | 1 000 |
| HB-22-250 | 250 | 553 | 1 000 |

1 Max. extension force for all stroke lengths 1800 N.

Ordering Example **HB-22-150-DD-M**

Type (Hydraulic Damper) _____
 Body \varnothing (23 mm) _____
 Stroke (150 mm) _____
 Piston Rod End Fitting D8 _____
 Body End Fitting D8 _____
 Damping Direction (M = out stroke only) _____

Damping Options

- P = Damping in both directions
- N = Damping on in stroke only
- M = Damping on out stroke only
- X = Special model suffix

The end fittings are interchangeable and must be positively secured by the customer to prevent unscrewing (i.e. Loctite). For mounting accessories see page 186.

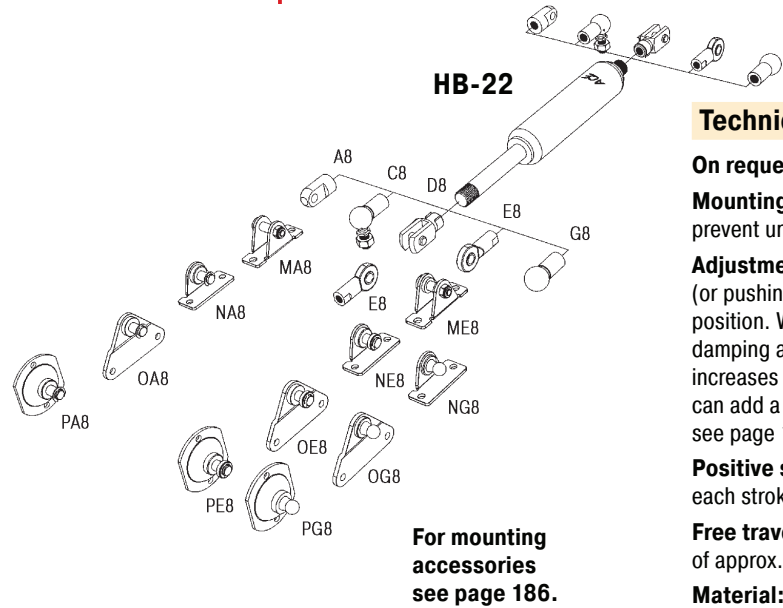

Technical Data

On request: Special lengths, alternative seals and end fittings.

Mounting: In any position. End fittings must be positively secured to prevent unscrewing.

Adjustment: Adjustment of the damping rate is achieved by pulling (or pushing) the piston rod to its fully extended (or compressed) position. Whilst still pulling the piston rod turn it clockwise to increase damping and anti-clockwise to decrease damping. If the resistance increases noticeably, stop adjusting to avoid damage. The adjustment can add a max. of 6 mm to the L dim. shown (adjustment instruction see page 145).

Positive stop: Provide mechanical stops 1 to 1.5 mm before end of each stroke direction.

Free travel: Construction of standard damper results in a free travel of approx. 20 % of stroke.

Material: Body: Black coated steel. Piston rod: With wear-resistant coating. End fittings: Zinc plated steel.

Separator piston: Available as a special option to remove free travel. Also provides extension force of min. 50 N. Dimension: L = 2.38 x stroke + 55 mm. Part number: Add suffix -T.

Issue 1.2013. Specifications subject to change

End Fitting

Standard Dimensions

End Fitting

A8 Eye A8 max. force 3000 N

B8 Stud Thread B8

C8 Angle Ball Joint C8 max. force 1200 N

D8 Clevis Fork D8 max. force 3000 N

E8 Swivel Eye E8 max. force 3000 N

G8 Ball Socket G8 max. force 1200 N

W8-28 Rod Shroud

Dimensions

| Type | Stroke mm | L extended | 1 Max. Compression Force N |
|-----------|-----------|------------|----------------------------|
| HB-28-100 | 100 | 263 | 3 000 |
| HB-28-150 | 150 | 363 | 3 000 |
| HB-28-200 | 200 | 463 | 3 000 |
| HB-28-250 | 250 | 563 | 3 000 |
| HB-28-300 | 300 | 663 | 2 500 |
| HB-28-350 | 350 | 763 | 2 000 |
| HB-28-400 | 400 | 863 | 1 500 |
| HB-28-500 | 500 | 1 063 | 1 000 |

1 Max. extension force for all stroke lengths 3000 N.

Ordering Example

HB-28-150-DD-M

Type (Hydraulic Damper) _____
 Body Ø (28 mm) _____
 Stroke (150 mm) _____
 Piston Rod End Fitting D8 _____
 Body End Fitting D8 _____
 Damping Direction (M = out stroke only) _____

Damping Options

- P = Damping in both directions
- N = Damping on in stroke only
- M = Damping on out stroke only
- X = Special model suffix

The end fittings are interchangeable and must be positively secured by the customer to prevent unscrewing (i.e. Loctite). For mounting accessories see page 186.

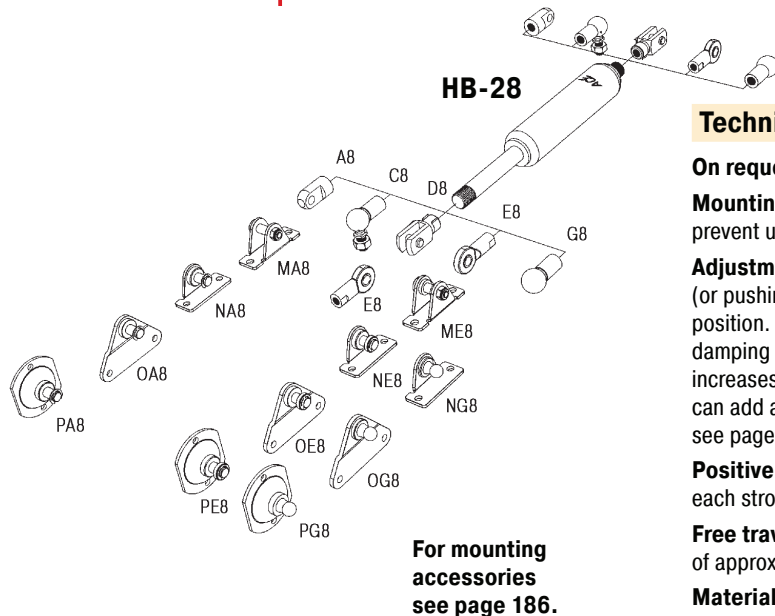

Technical Data

On request: Special lengths, alternative seals and end fittings.

Mounting: In any position. End fittings must be positively secured to prevent unscrewing.

Adjustment: Adjustment of the damping rate is achieved by pulling (or pushing) the piston rod to its fully extended (or compressed) position. Whilst still pulling the piston rod turn it clockwise to increase damping and anti-clockwise to decrease damping. If the resistance increases noticeably, stop adjusting to avoid damage. The adjustment can add a max. of 6 mm to the L dim. shown (adjustment instruction see page 145).

Positive stop: Provide mechanical stops 1 to 1.5 mm before end of each stroke direction.

Free travel: Construction of standard damper results in a free travel of approx. 20 % of stroke.

Material: Body: Black coated steel. Piston rod: With wear-resistant coating. End fittings: Zinc plated steel.

Separator piston: Available as a special option to remove free travel. Also provides extension force of min. 80 N. Dimension: L = 2.35 x stroke + 60 mm. Part number: Add suffix -T.

End Fitting

Standard Dimensions

End Fitting

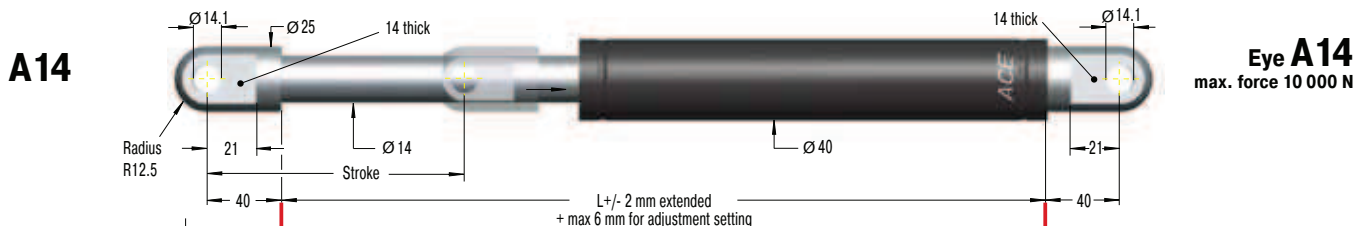

B14

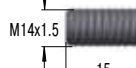

Stud Thread B14

C14

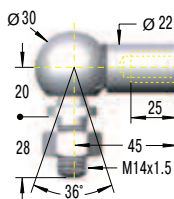

Angle Ball Joint C14

max. force 3200 N

D14

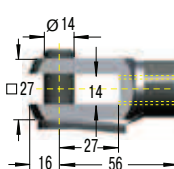

Clevis Fork D14

max. force 10000 N

E14

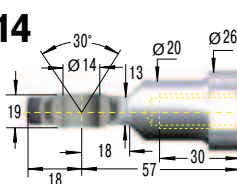

Swivel Eye E14

max. force 10000 N

Dimensions

| Type | Stroke mm | L extended | 1 Max. Compression Force N |
|-----------|-----------|------------|----------------------------|
| HB-40-100 | 100 | 275 | 10 000 |
| HB-40-150 | 150 | 375 | 10 000 |
| HB-40-200 | 200 | 475 | 10 000 |
| HB-40-300 | 300 | 675 | 10 000 |
| HB-40-400 | 400 | 875 | 8 000 |
| HB-40-500 | 500 | 1 075 | 6 000 |
| HB-40-600 | 600 | 1 275 | 4 000 |
| HB-40-700 | 700 | 1 475 | 3 000 |
| HB-40-800 | 800 | 1 675 | 3 000 |

1 Max. extension force for all stroke lengths 10 000 N.

Ordering Example

Type (Hydraulic Damper) _____
 Body Ø (40 mm) _____
 Stroke (300 mm) _____
 Piston Rod End Fitting E14 _____
 Body End Fitting E14 _____
 Damping Direction (N = in stroke only) _____

HB-40-300-EE-N

Damping Options

- P = Damping in both directions
- N = Damping on in stroke only
- M = Damping on out stroke only
- X = Special model suffix

Rod Shroud W14-40

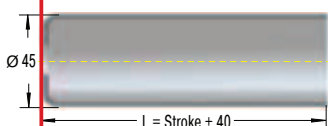

The end fittings are interchangeable and must be positively secured by the customer to prevent unscrewing (i.e. Loctite). For mounting accessories see page 187.

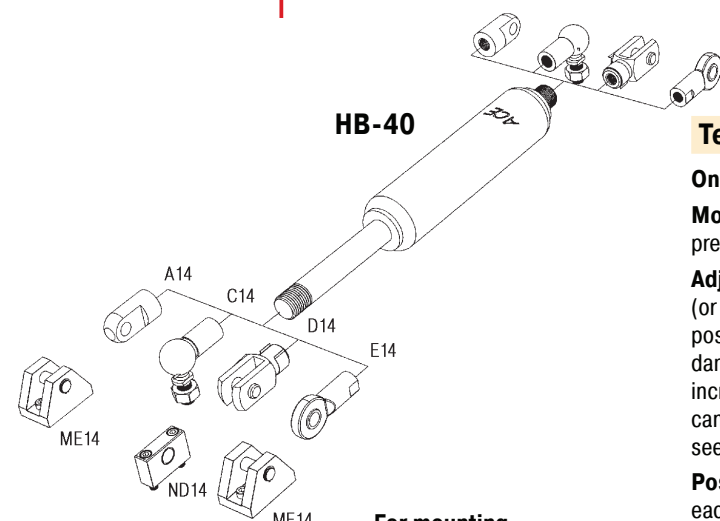

For mounting accessories see page 187.

Technical Data

On request: Special lengths, alternative seals and end fittings.

Mounting: In any position. End fittings must be positively secured to prevent unscrewing.

Adjustment: Adjustment of the damping rate is achieved by pulling (or pushing) the piston rod to its fully extended (or compressed) position. Whilst still pulling the piston rod turn it clockwise to increase damping and anti-clockwise to decrease damping. If the resistance increases noticeably, stop adjusting to avoid damage. The adjustment can add a max. of 6 mm to the L dim. shown (adjustment instruction see page 145).

Positive stop: Provide mechanical stops 1 to 1.5 mm before end of each stroke direction.

Free travel: Construction of standard damper results in a free travel of approx. 20 % of stroke.

Material: Body: Black coated steel. Piston rod: With wear-resistant coating. End fittings: Zinc plated steel.

Separator piston: Available as a special option to remove free travel. Also provides extension force of min. 150 N. Dimension: L = 2.32 x stroke + 82 mm. Part number: Add suffix -T.

End Fitting

Standard Dimensions

End Fitting

B24

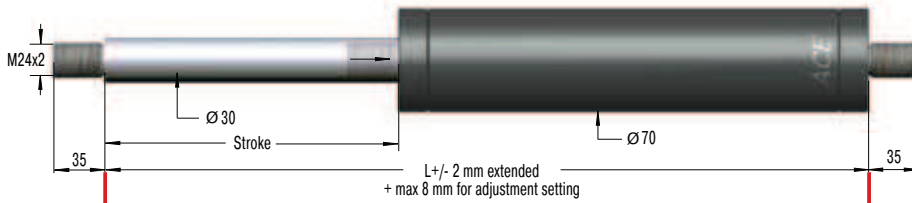

Stud Thread **B24**

D24

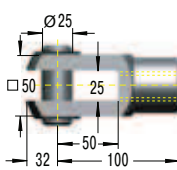

Clevis Fork **D24**
max. force 50 000 N

E24

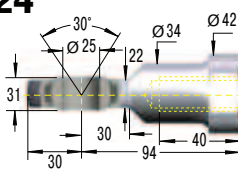

Swivel Eye **E24**
max. force 50 000 N

Dimensions

| Type | Stroke mm | L extended | ¹ Max. Compression Force N |
|-----------|--------------|---------------|---|
| HB-70-100 | 100 | 320 | 50 000 |
| HB-70-200 | 200 | 520 | 50 000 |
| HB-70-300 | 300 | 720 | 50 000 |
| HB-70-400 | 400 | 920 | 30 300 |
| HB-70-500 | 500 | 1 120 | 21 600 |
| HB-70-600 | 600 | 1 320 | 16 200 |
| HB-70-700 | 700 | 1 520 | 12 600 |
| HB-70-800 | 800 | 1 720 | 10 100 |

¹ Max. extension force for all stroke lengths 50 000 N.

Ordering Example

Type (Hydraulic Damper) _____
 Body Ø (70 mm) _____
 Stroke (300 mm) _____
 Piston Rod End Fitting E24 _____
 Body End Fitting E24 _____
 Damping Direction (N = in stroke only) _____

HB-70-300-EE-N

Damping Options

- P = Damping in both directions
- N = Damping on in stroke only
- M = Damping on out stroke only
- X = Special model suffix

The end fittings are interchangeable and must be positively secured by the customer to prevent unscrewing (i.e. Loctite). For mounting accessories see page 187.

Rod Shroud
W24-70

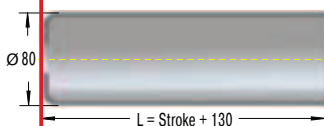

Technical Data

On request: Special lengths, alternative seals and end fittings.

Mounting: In any position. End fittings must be positively secured to prevent unscrewing.

Adjustment: Adjustment of the damping rate is achieved by pulling (or pushing) the piston rod to its fully extended (or compressed) position. Whilst still pulling the piston rod turn it clockwise to increase damping and anti-clockwise to decrease damping. If the resistance increases noticeably, stop adjusting to avoid damage. The adjustment can add a max. of 8 mm to the L dim. shown (adjustment instruction see page 145).

Positive stop: Provide mechanical stops 5 to 6 mm before end of each stroke direction.

Free travel: Construction of standard damper results in a free travel of approx. 20% of stroke.

Material: Body: Black coated steel or zinc plated steel. Piston rod: Hard chrome plated. End fittings: Zinc plated steel.

Separator piston: Available as a special option to remove free travel. Also provides extension force of min. 250 N. Increases dimension L + 150 mm. Part number: Add suffix -T.

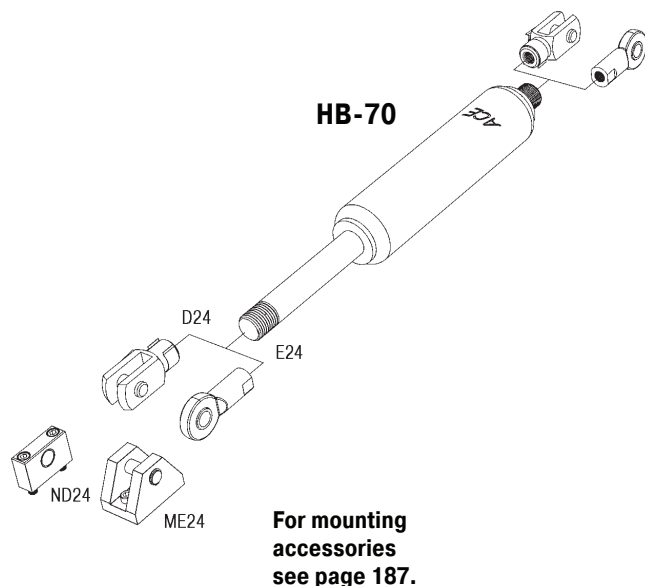

For mounting accessories see page 187.

Adjustment Instructions for HB-12 to HB-70 and HBS-28 to HBS-70



View in direction of arrow

Adjustment only possible when piston rod is **fully** extended or **fully** compressed.

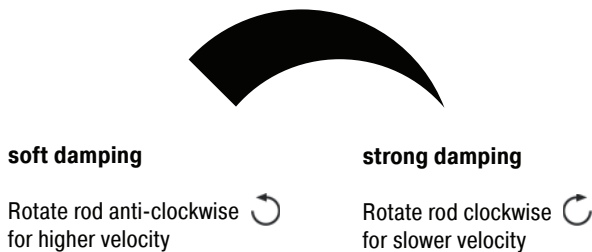

1. Hold outer body.
2. a) When piston rod is fully extended:
Adjust damping by turning the piston rod as shown in the picture. Whilst rotating, pull the piston rod gently, to ensure the adjuster locates in the end cap.
b) When the piston rod is fully compressed:
Adjust the damping by turning the piston rod as shown in the picture. Whilst rotating, push the piston rod gently, to ensure the adjuster locates in the end cap.
3. When resistance is felt when rotating the piston rod, stop turning. You will be at the end of the adjustment.
NOTE: Do not rotate piston rod too quickly as damage could occur.
4. Check the damping, if required repeat step 1 to 3.
5. On all versions with a separator piston (type "T") adjustment is only possible when the piston rod is extended (adjustment 2a).