

浮动接头



CAD 2D/3D

①代号	类型	主体M材质		表面H硬度	S表面处理	弹簧M材质	
		国标	相当				
FNFIAA	内螺纹型	圆法兰型	45	S45C	43~48HRC	发黑	弹簧钢
FNFIABA			9Cr18Mo	SUS440C	750HV~	镀硬铬	不锈钢弹簧钢
FNFIAB		对边法兰型	45	S45C	43~48HRC	发黑	弹簧钢
FNFIACA			9Cr18Mo	SUS440C	750HV~	镀硬铬	不锈钢弹簧钢
FNFIADA			45	S45C	43~48HRC	发黑	弹簧钢
FNFIABA	外螺纹型	圆法兰型	45	S45C	43~48HRC	发黑	弹簧钢
FNFEABA			9Cr18Mo	SUS440C	750HV~	镀硬铬	不锈钢弹簧钢
FNFEAB		对边法兰型	45	S45C	43~48HRC	发黑	弹簧钢
FNFEACA			9Cr18Mo	SUS440C	750HV~	镀硬铬	不锈钢弹簧钢
FNFEADA			45	S45C	43~48HRC	发黑	弹簧钢
FNFEBA	9Cr18Mo	SUS440C	750HV~	镀硬铬	不锈钢弹簧钢		

标准加工

注:请在螺纹孔深度范围内拧入螺栓,否则,将导致动作不良,单方向持续施加负载,可能会造成难以吸收偏心。

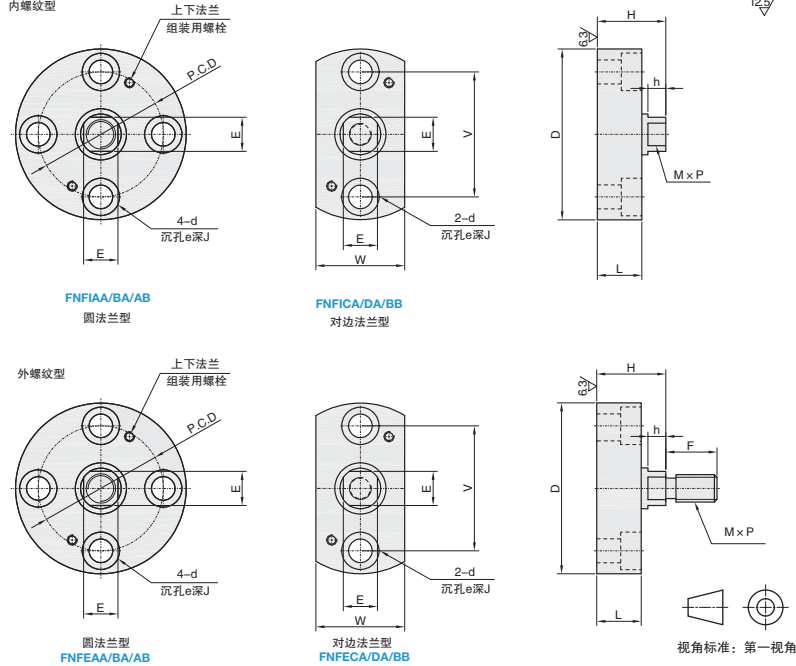

①代号 - ②M
FNFIAA - M8

内螺纹型

①代号	②M	螺距	F	E	h	D	H	L	P.C.D	e	i	L	W	V	容许偏心量	容许偏心角度	K	最大负载	重量	
																			圆法兰型	对边法兰型
圆法兰型 FNFIAA FNFIABA FNFIAB FNFIACA FNFIADA FNFIABB	3	0.5	11	7	3.2	39	14	10	28.6	4.5	8	5	21	28.6	0.5	3	0.45	28	78	51
	4	0.7			80	77	50													
	5	0.8	12.5	4.2	44	16	10.5	32.1	6	9.5	5.5	23	32.1	0.95	4	0.65	200	106	69	
	6	1			105	68														
	8	1.25	16	10	5.2	50	20	13	36.6	7	11	6	26	36.6	1.1	0.95	800	166	109	
	10	1.25	20	12	6.2	52	25	17	38.6	28	38.6	236	157							
	12	1.5	23	17	7.2	66	28	19.5	49.6	9	14	8	36	49.6	1	5	1.4	4400	411	274
	14		23	17	7.2	66	28	19.5	49.6									36	49.6	402
	16	1.5	30	22	9.2	70	35	24.5	53.6	9	14	8	40	53.6	1	5	1.5	6400	553	372
	18		30	22	9.2	70	35	24.5	53.6									40	53.6	538
20	2.5	38	27	10.2	88	45	31.5	68.1	12	18	10	51	68.1	1.5	1.9	1.9	8800	1078	735	
22		38	27	10.2	88	45	31.5	68.1									12	18	10	51

外螺纹型

①代号	②M	螺距	F	E	h	D	H	L	P.C.D	e	i	L	W	V	容许偏心量	容许偏心角度	K	最大负载	重量	
																			圆法兰型	对边法兰型
圆法兰型	5	0.8	10	7	4.2	44	16	10.5	32.1	6	9.5	5.5	23	32.1	0.5	4	0.65	200	103	67
FNFEAA	6	1	12																105	69
FNFEABA	8	1.25	15	10	5.2	50	20	13	36.6	7	11	6	26	36.6	0.5	0.95	0.95	800	173	113
FNFEAB																			10	1.5
对边法兰型	12	1.5	18	17	7.2	66	28	19.5	49.6	9	14	8	36	49.6	1	5	1.4	4400	445	298
FNFECA	16	2	20	22	9.2	70	35	24.5	53.6										40	53.6
FNFECA	20	2.5	25	27	10.2	88	45	31.5	68.1	12	18	10	51	68.1	1.5	1.9	1.9	8800	653	457
FNFEBA																			20	2.5

L2 浮动接头