

# 垂直式快速夹钳

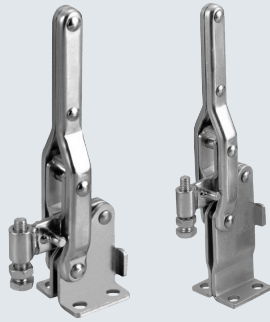

★ 产品特点：主体材质Q235，压把开启角度为129°，手柄开启角度为75.5°

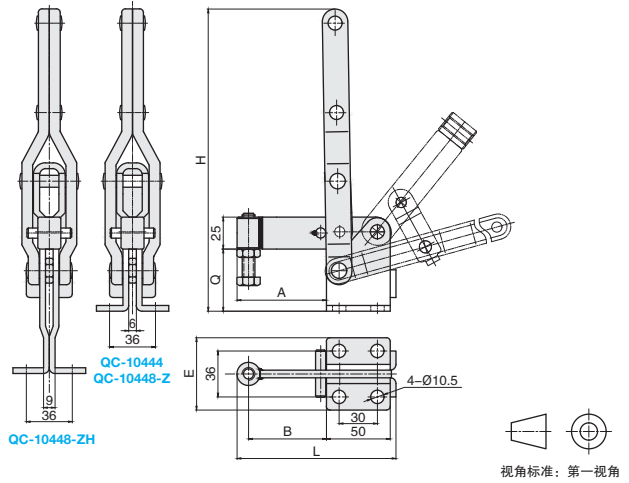

①代号  
**QC1-10444**

①代号	夹持力	压头型号	自重	A	B	E	L	Q	H
<b>QC1-10444</b>	400kg	QC-SA-38200	870g	70	61	56.6	124.5	48.7	236.7
<b>QC1-10448-Z</b>			840g	37	28.1	56.6	91.5	48.7	236.7
<b>QC1-10448-ZH</b>			1000g	37	28.1	57	91.6	97.5	285.5



★ 产品特点：主体材质Q235，压把开启角度为95°，手柄开启角度为65°

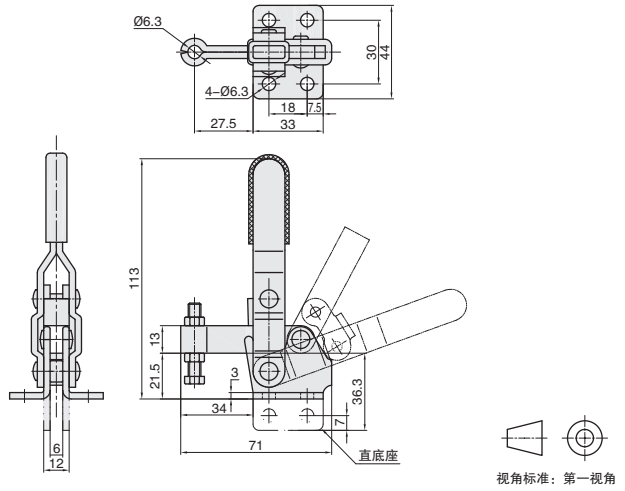

①代号  
**QC1-11401**

①代号	底座样式	把手样式	夹持力	压头型号	自重
<b>QC1-11401</b>	平面法兰底座	直把手	100kg	QC-SA-064010	200g
<b>QC1-12401</b>	直底座	直把手			