

水平式快速夹钳

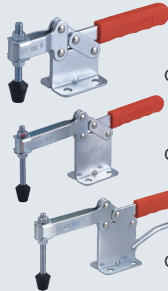

QC-200-W

QC-200-WLH

QC-220-WLH

★ 产品特点：主体材质Q235，压把开启角度为75°，手柄开启角度为77°

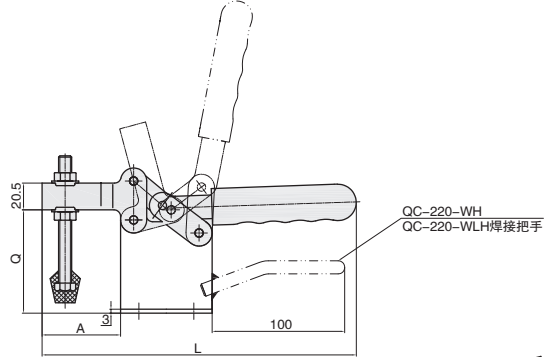
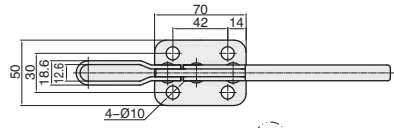

视角标准：第一视角



①代号
QC2-200-W

①代号	压把样式	底座样式	夹持力	压头型号	自重	A	L	Q
QC2-200-W	U形槽	平面法兰底座	400kg	QC-FC-38312	600g	60	240	54
QC2-200-WL				640g	110	290	54	
QC2-220-WH				790g	60	240	79	
QC2-220-WLH				830g	110	290	79	

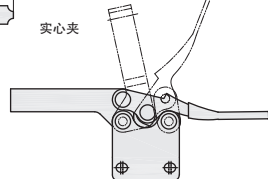
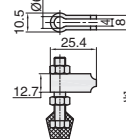
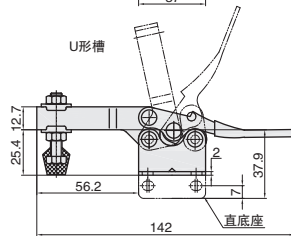
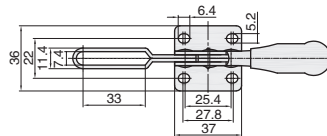

视角标准：第一视角

★ 产品特点：主体材质Q235，压把开启角度为85°，手柄开启角度为60°



①代号
QC2-201-B

①代号	压把样式	底座样式	夹持力	压头型号	自重
QC2-201-B	U形槽	平面法兰底座	90kg	QC-FC-14134	130g
QC2-201-BI	U形槽	直底座			
QC2-201-BS	实心夹	平面法兰底座			
QC2-201-BSI	实心夹	直底座			
QC2-201-BSS	尺寸同QC2-201-B，主体材质为不锈钢				