

水平式快速夹钳

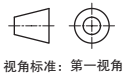

★ 产品特点：主体材质 Q235，压把开启角度为 94°，手柄开启角度为 76°

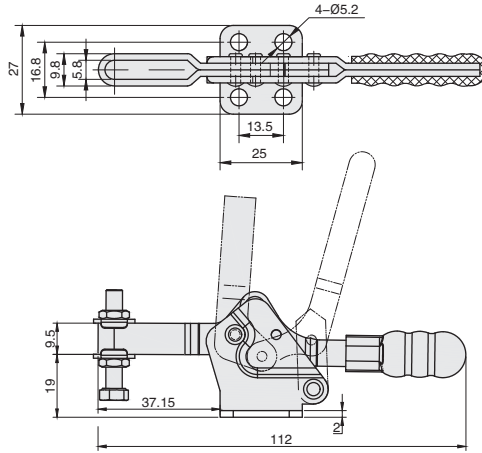

① 代号
QC2-20752-B

① 代号	夹持力	压头型号	自重	A	L	N	P	Q	T	X	Y	Z
QC2-20752-B	75kg	QC-SA-053008	88g	37	116	27	9.5	19	2	9.8	5.8	25
QC2-21502-B	150kg	QC-SA-064010	220g	61.8	171	40	14	25	2.5	11.2	6.2	38
QC2-22502-B	250kg	QC-SA-085012	430g	79	219	47	17.5	34	3	15	9	42