

水平式快速夹钳

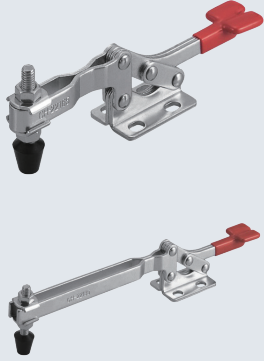

★ 产品特点：主体材质Q235，压把开启角度为96°，手柄开启角度为88°

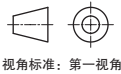
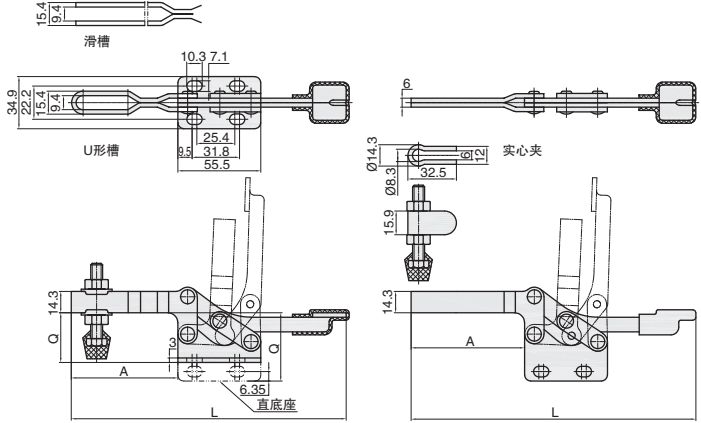

视角标准：第一视角



① 代号
QC2-22165

① 代号	压把样式	底座样式	夹持力	压头型号	自重	A	L	Q
QC2-22165	U形槽	平面法兰底座	250kg	QC-FC-56212	285g	71.4	185	33.3
QC2-22185	滑槽	平面法兰底座			360g	167	280	28.6



★ 产品特点：主体材质Q235，压把开启角度为100°，手柄开启角度为94°

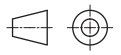
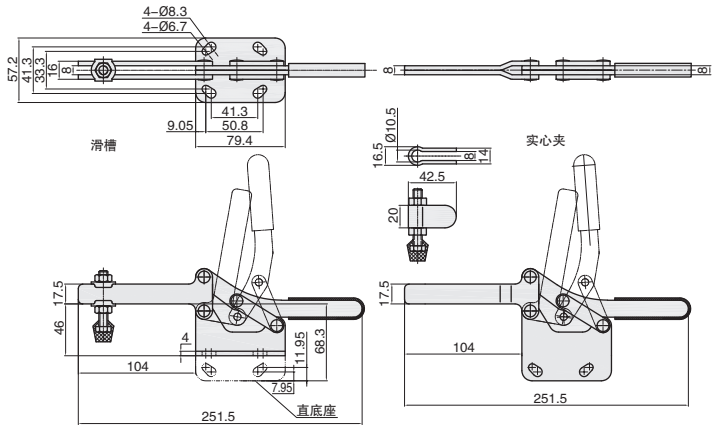

视角标准：第一视角



① 代号
QC2-22235

① 代号	压把样式	底座样式	夹持力	压头型号	自重
QC2-22235	滑槽	平面法兰底座	273kg	QC-FC-56212	640g