

★ 产品特点: 主体材质是聚缩醛树脂, 刚度高, 耐磨性好, 可用于食品行业。与标准型相比, 公差范围大, 如需要更高精度, 请选用标准型。

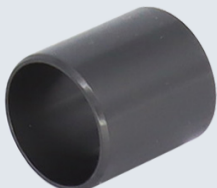

①代号	④材质	配套轴公差	配套孔公差	使用温度范围 (°C)
OFEBZ	聚缩醛树脂 含润滑剂与特殊填充剂	h9	H7	-40~80

▲ 基座孔推荐公差: H7;  
 ▲ 配套轴公差推荐: h9。  
 ▲  $L \leq 10$ 时, L公差为 $L_{0.3}^0$ 。  
 ▲  $L > 10$ 时, L公差为 $L_{0.5}^0$ 。

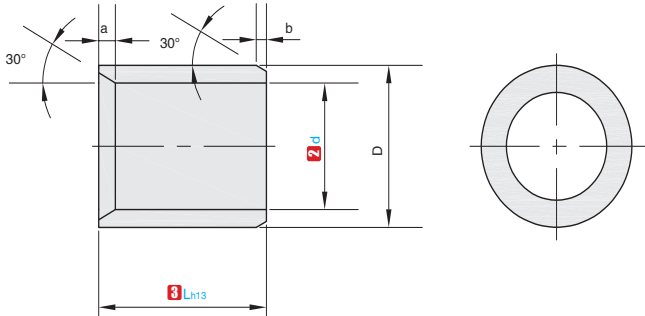

视角标准: 第一视角



①代号 - ②d - ③L  
OFEBZ - d12 - L15

①代号	型号		③L(h13)								D	倒角				
	②d		3	5	6	8	10	11	12	15		18	20	25	30	a
OFEBZ	3	+0.054 +0.014	3	5	6									4.5	0.3	
	4		4	6	8									5.5		
	5	+0.068 +0.020		5	8	10	12				18			7		
	6		4	5	6	8	10	11						8		
	8			5	6	8	10	11	12	15				10		
	10	+0.083 +0.025		4	5	6	8	10	12	15	18	20		12		
	10A										16			14		
	12				6	8	10	12	15		20	25	30	14	0.8	
	14				8	10	12	15		20	25			16		
	15	+0.102 +0.032			10	12	15	17	20	25				17		
	16				10	12	15		20	25				18		
	18						15		20	25				20		
	20						12	15			28			22		
	20A				10		15		20	23	25	30		23		
	22	+0.124 +0.040					15		20	25	30			25		
	25				10	12	15		20	25	30			28		
	30								20	25	30	40		34		
	35							15	20	25	30	40	50	39		
	40	+0.150 +0.050							20		30	40	50	44	1.2	
	45										30	40	50	50		
50				10				20		30	40	50	55			

▲ d公差为压入标准H7座孔(ISO3547-1)后公差。



交货期

5天发货



数量	1-9	10~
折扣率	100%	现询