

★ 产品特点: 主体材质是聚四氟乙烯, 刚度好, 耐磨性好, 可用于食品行业。耐腐蚀, 耐低温和高温。

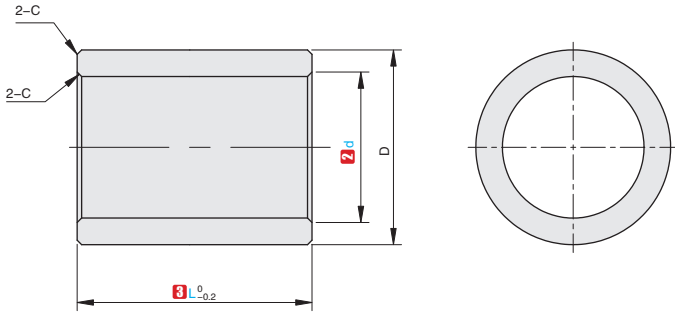

①代号	M材质	配套轴公差	配套孔公差	使用温度范围(°C)
OFPBZ	聚四氟乙烯树脂 含润滑剂与特殊填充剂	g6	H7	-200~200

▲ 底座孔推荐公差: H7  
 ▲ 配套轴公差推荐: g6  
 ▲ L≤8时, L公差为 $0_{-0.2}$   
 ▲ L>8时, L公差为 $0_{-0.25}$



视角标准: 第一视角



①代号 - ②d - ③L  
OFPBZ - d3 - L3

型号	d压入前公差	③L	D	D公差	压入后 内径公差	C	
OFPBZ	③	+0.179	3 5	6	+0.09 +0.04	+0.12 +0.07	0.3
	④	+0.129	3 5 8	7		+0.122 +0.072	
	⑤		5 8 10	8			
	⑥	+0.182 +0.132	5 8 10	9	+0.10 +0.05	+0.131 +0.081	0.5
	⑧	+0.197 +0.147	8 10 12 15	12		+0.144 +0.094	
	⑩	+0.210 +0.160	8 10 12 15	14			
	⑫	+0.212 +0.162	10 12 15 20	16		+0.175 +0.105	
	⑯	+0.239 +0.169	12 15 20 25	22	+0.11 +0.06		+0.229 +0.109
⑰	+0.303 +0.183	15 20 25 30	26				



交货期

5天发货



数量	1-9	10~
折扣率	100%	现询