

# 高品标准型

## ■ 直筒螺帽型

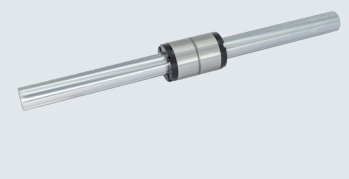

①代号	类型	材质				硬度	表面处理
		花键轴		花键套			
		国标	相当	国标	相当		
HQ-BSCN	直筒螺帽型	GCr15	SUJ2	GCr15	SUJ2	HRC58-	-

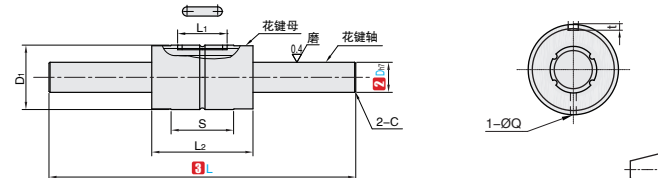

视角标准：第一视角





①代号 - ②D - ③L  
 HQ-BSCN - D8 - L200

型号		花键轴			花键套				基本额定负载 (kgf)		基本额定扭矩 (kgf·m)		容许静力矩 (kgf·m)		重量			
①代号	②D <sub>H7</sub>	③L最小单位1	d	滚珠列数	D <sub>1</sub>	L <sub>1</sub>	L <sub>2</sub>	Q油孔	键槽尺寸		C	C <sub>O</sub>	C <sub>T</sub>	C <sub>OT</sub>	MA <sub>1</sub>	MA <sub>2</sub>	花键套 g	花键轴 kg/m
									b	t								
HQ-BSCN	6	0	60-500	2	14	10.5	25	1	2.5	1.2	122	228	0.15	0.24	0.51	4	19	0.21
	8	-0.011		3	16	10.5	25	1.5	2.5	1.2	145	287	0.6	0.99	0.74	5	23	0.38
	10	0		4	21	13	33	1.5	3	1.5	2.73	507	1.62	2.25	1.8	11.6	54	0.6
	13	-0.013	6	24	15	36	1.5	3	1.5	2.67	489	2.89	3.94	1.37	10.9	70	1	
	16	0	70-700	8	31	17.5	50		3.5	2	612	1120	4.77	7.43	4.6	29.9	150	1.5
	20	-0.016		10	35	29	63	2	4	2.5	890	1630	7.9	12.09	11	56	220	2.4
	25	0	80-800	15	42	36	71	3	4	2.5	1003	1593	21.99	43.01	10.35	68.59	285	3.8
	30	0	100-1250	-	47	42	80	3	4	2.5	1160	1980	30.26	62.93	15.68	93.27	395	5.49
	40	-0.025	120-1500	-	64	52	100	4	6	3.5	2972	4033	105.37	176.05	36.59	264.34	843	9.69
	50	0	140-1700	-	80	58	125	4	8	4	4086	5615	179.89	304.35	51.58	428.72	1758	15.19

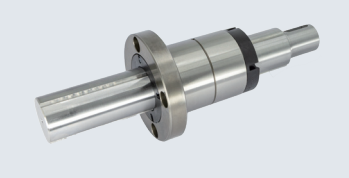
## ■ 法兰螺帽型

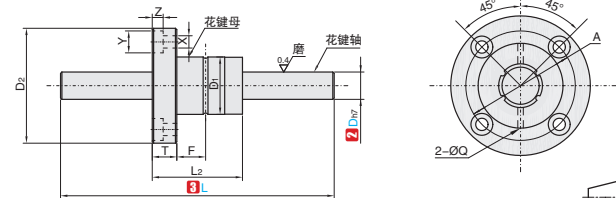

①代号	类型	材质				硬度	表面处理
		花键轴		花键套			
		国标	相当	国标	相当		
HQ-BSFN	法兰螺帽型	GCr15	SUJ2	GCr15	SUJ2	HRC58-	-



视角标准：第一视角



①代号 - ②D - ③L  
 HQ-BSFN - D8 - L200

型号		花键轴			花键套							基本额定负载 (kgf)		基本额定扭矩 (kgf·m)		容许静力矩 (kgf·m)		重量					
①代号	②D <sub>H7</sub>	③L最小单位1	d	滚珠列数	D <sub>1</sub>	L <sub>2</sub>	D <sub>2</sub>	A	T	F	Q油孔	安装孔			C	C <sub>O</sub>	C <sub>T</sub>	C <sub>OT</sub>	MA <sub>1</sub>	MA <sub>2</sub>	花键套 g	花键轴 kg/m	
												X	Y	Z									
HQ-BSFN	6	0	60-500	2	14	25	30	22	6	7.5	1	3.4	6.5	4.5	137	225	0.46	0.76	0.39	3.48	36.7	0.22	
	8	-0.015		3	16	27	32	24	8		1.5					1003	1593	0.6	0.99	0.95	3.82	47	0.39
	10	0		4	21	33	42	32	9	10.5			4.5	8	4	285	397	1.62	2.25	0.95	8.53	100	0.6
	13	-0.018	6	24	36	44	33		11						4.5	396	540	2.89	3.94	1.5	12.46	117	1.03
	16	0	70-700	8	31	5	51	40		18	2				6	545	849	4.77	7.43	3.71	26.09	226	1.56
	20	-0.021		10	35	56	58	42					5.4	9.5	8	724	1109	7.9	12.09	5.53	38	303	2.44
	25	0	80-800	15	42	71	65	52	13	26.5	3	5.5	9.5			1003	1593	21.99	43.01	10.35	68.59	458	3.8
	30	-0.021	90-1000	-	47	80	75	60		30		6.6	11			1160	1980	30.26	62.93	15.68	93.27	633	5.49
	40	0	100-1250	-	64	100	100	82	18	36	4	9	14	12	2972	4033	105.37	176.05	36.59	246.34	1430	9.69	
	50	-0.025	120-1500	-	80	125	124	102	20	46.5	4	11	17.5	12	4086	5615	179.89	304.35	51.58	428.72	2756	15.19	

▲ 容许静力矩MA1为使用1个螺帽时的数值；MA2为使用两个紧密接触的螺帽时的数值

	交货期	<b>7天发货</b>		数量	1~9	10~
				价格	100%	现询