

## No. 6918-100

### Delay valve

For O-ring connection, for the release clamping circuit, max. operating pressure 350 bar, min. operating pressure 35 bar.



CAD

| Order no. | Article no. | Setting range *** for the delay [s] | Q max. [l/min] | Filter mesh [μm] | OR-1 O-ring Order No. | Weight [g] |
|-----------|-------------|-------------------------------------|----------------|------------------|-----------------------|------------|
| 556992    | 6918-100    | 3-7                                 | 11,4           | 25               | 474429                | 1970       |

\*\*\* The duration of the delay can vary, depending on the viscosity of the oil in the application. This statement is valid with ISO 32 Oil.

### Design:

Delay valve with NG 6. The hole pattern is not standardised. Valve housing made of steel, interior parts made of stainless steel. The fastening bolts M6x60 (order no. 115634) are not supplied as standard. Oil supply via oil channel in fixture body.

### Application:

With this valve, unclamping of selected components can be delayed during the release process. The delay can be achieved within a circuit. A parallel circuit with several delay valves is possible.

### Features:

In the release process, hydraulic clamping and support elements or workpieces can be protected from overload. The consumers can be selectively controlled through a controlled sequence of the pressure reduction in the clamping circuit.

### Note:

Observe installation instructions with construction notes for the fixture manufacturer. The flange surface of the fixture must have an evenness of 0.08 and a surface quality of Rz 6.3.

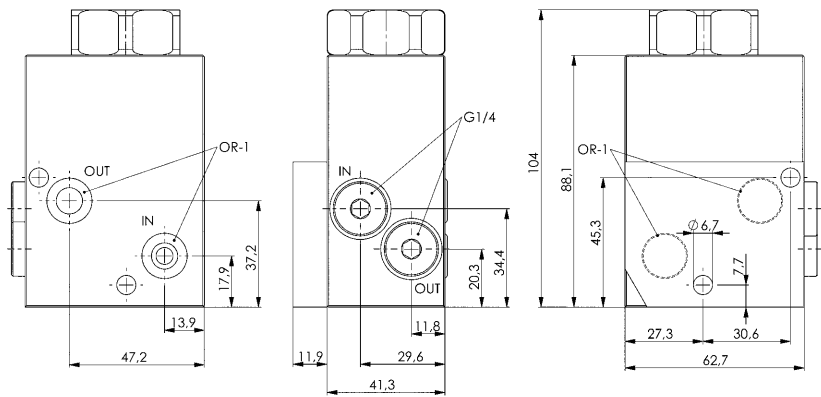
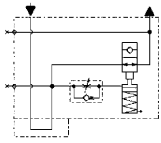

### Application example:

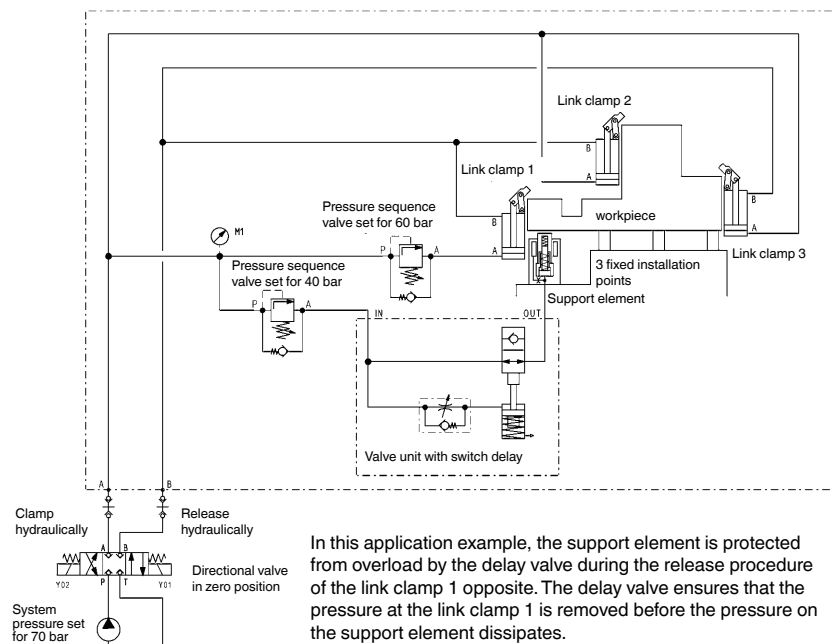

Subject to technical alterations.