

No. 6970CD

Bore clamp MAXI, hydraulic, centric

Double-acting,
max. operating pressure 150 bar,
min. operating pressure 40 bar,
lateral compensation per clamp ± 0.25 mm.

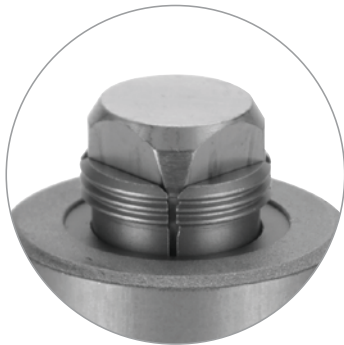
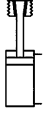

Order no.	Article no.	Clamping force vertical at 100 bar [kN]	Clamping force vertical at 150 bar [kN]	Clamping rim height min. for Al-alloy [mm]	dia. K	L	Md [Nm]	Weight [g]
556565	6970CD-08	2,76	4,1	5	7,8 - 8,6	9	3,7	298
556566	6970CD-09	4,4	6,6	6	8,7 - 9,6	9	7,2	413
556567	6970CD-10	4,4	6,6	6	9,7 - 10,7	9	7,2	413
556568	6970CD-11	5,0	7,5	8	10,8 - 11,8	9	10,0	530
556569	6970CD-12	5,0	7,5	8	11,9 - 12,8	9	10,0	532
556570	6970CD-13	5,0	7,5	8	12,9 - 13,8	9	10,0	535

Design:

The actuating piston is double-acting. Body, clamping segments and tension bolts are made of nitrided tempered steel. Four-part clamping segments are externally interlocked. Four fastening screws are supplied as standard. Oil supply via oil channel in fixture body.

Application:

The hydraulic bore clamp is preferred for use on workpieces with complex external geometries that must be clamped for machining. After the clamping segments are applied to single-attachment clamping holes with low depth, a secure 5-sided processing can be performed without difficulty. Workpieces can be installed or removed automatically with handling devices.

Features:

The tension bolt has the shape of a four-sided pyramid at the coupling point to the clamping sleeve. The clamping sleeve segments have this shape also, thus ensuring the sleeve segments have contact on the entire surface in every position of the tension bolt. This facilitates a high clamping power and ensures very low wear. Elastic rings hold the clamping segments together and seal them against entry of chips. Depending on the material, the external serration is pressed into the clamping hole with more or less force, thus permitting the required positive fit. The built-in plate springs achieve a max. pull-down stroke of approx. 0.2 mm during clamping. The integrated air connection L1 is used for cleaning the clamping area. This blow-off can also be used as a mount check for blind holes.

The integrated air connection is used for cleaning the clamping control. With a suction volume flow meter, the volume flow is measured in the unclamped and clamped state of the workpiece. The difference is used for clamping control. The max. operating pressure should not exceed 6 bar here.

The tension bolt has a pyramid shape for better pre-positioning of the workpieces. The drill clamp is also a contact surface for the workpiece. The workpiece contact surface is hard-metal coated ($\mu = 0.3$), which markedly increases the displacement force.

Note:

The lateral force when inserting the workpiece must not exceed the "lateral force" table value. The radial force must be observed.

Please contact us if clamping hardened or cast workpieces.

On request:

Bore clamps for other hole diameters available upon request.

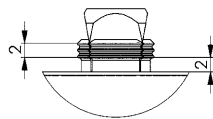

Clamping hole in workpiece:

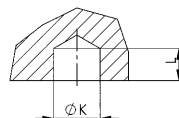

CAD



Subject to technical alterations.

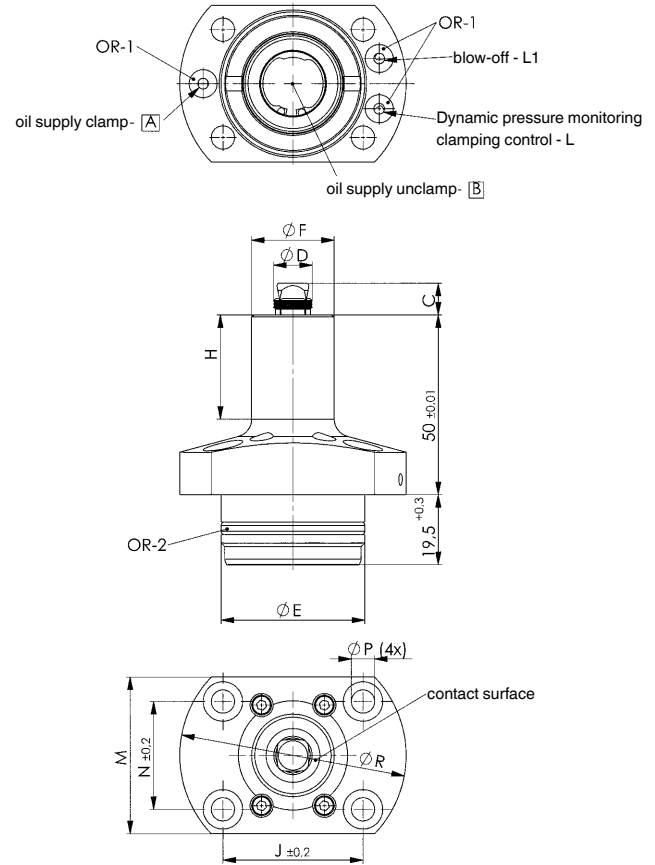

Dimensions:

Order no.	Article no.	Displacement force horizontal at 100 bar [kN]	Displacement force horizontal at 150 bar [kN]	Clamping sleeve radial force at 100 bar [kN]	Clamping sleeve radial force at 150 bar [kN]	Vol. Sp [cm ³]	Vol. Lo [cm ³]	C	dia. D	dia. E	dia. F	H	J	M	N	P	R	OR-1 O-ring Order No.	OR-2 O-ring Order No.
556565	6970CD-08	0,83	1,23	7,85	11,78	1,10	1,26	8,5	7,6	30	18	31,5	31	32,6	23	4,5	51	176164	490342
556566	6970CD-09	1,32	1,98	12,47	18,71	1,76	1,96	8,8	8,6	37	20	31,5	38	39,6	29	5,5	60	161802	492728
556567	6970CD-10	1,32	1,98	12,47	18,71	1,76	1,96	8,8	9,6	37	20	31,5	38	39,6	29	5,5	60	161802	492728
556568	6970CD-11	1,51	2,26	14,26	21,39	2,01	2,46	8,8	10,7	40	23	29,0	39	43,6	30	6,5	63	161802	321117
556569	6970CD-12	1,51	2,26	14,26	21,39	2,01	2,46	8,8	11,7	40	23	29,0	39	43,6	30	6,5	63	161802	321117
556570	6970CD-13	1,51	2,26	14,26	21,39	2,01	2,46	8,8	12,7	40	23	29,0	39	43,6	30	6,5	36	161802	321117

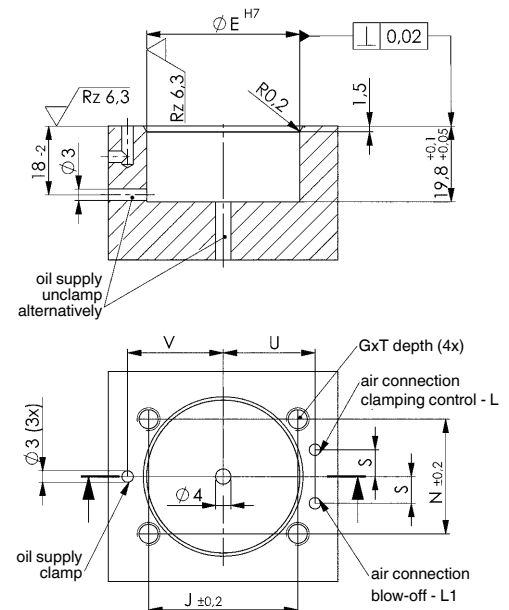

Installation dimensions:

Order no.	Article no.	ØE H7	G	S	T	U	V
556565	6970CD-08	30	M4	5,5	8	24	25
556566	6970CD-09	37	M5	7,0	10	24	25
556567	6970CD-10	37	M5	7,0	10	24	25
556568	6970CD-11	40	M6	7,0	12	24	25
556569	6970CD-12	40	M6	7,0	12	24	25
556570	6970CD-13	40	M6	7,0	12	24	25

Subject to technical alterations.