

No. 6992H-21

Rotary coupling

controlled, double-acting.
One loading and unloading station,
max. operating pressure 350 bar

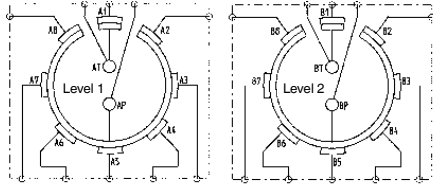

Order no.	Article no.	Connections inputs loading	Connections inputs processing	Connections outputs loading	Connections outputs processing	Ambient temp. [°C]	Q max. [l/min]	NG	Weight [Kg]
324566	6992H-21-06	2	2	2	10	-10 - +60	8	5	4,1
324574	6992H-21-08	2	2	2	14	-10 - +60	8	5	4,0
324582	6992H-21-10	2	2	2	18	-10 - +60	8	5	3,9

Design:

Rotary feed-through housing from spheroid graphite iron with radial oil connections 1/4" thd. Rotary piston from nitrided, hardened steel with radial and front oil connections 1/4" thd. The reductions in the face side connections can be used as O-ring connections.

Application:

Rotary couplings transmit flows of hydraulic oil from a stationary machine component to a rotating one. They are located in the rotary axis of a rotating system. The controlled rotary couplings may only be operated with hydraulic oil. Types 6992H-21 are designed for double-acting cylinders. One double-acting loading/unloading station and 5, 7 or 9 double-acting processing stations can be connected.

Features:

Rotary vane construction. Multiple hydraulic cylinders are supplied with hydraulic oil simultaneously. At the same time, a loading and/or unloading station can be controlled via directional valves for clamping and/or unclamping. High operating pressures due to high-quality components and seals. Compact design. Long service life.

Note:

The controlled rotary couplings can only be used for cyclic operation or at very low rpms. The rotary couplings must be operated without bending forces. In contrast to the uncontrolled versions, we recommend that you screw the rotating housing with the connections to the clamping fixtures, and to secure the rotary pistons only against twisting. Do not introduce any bearing loads! The connections to the rotary pistons must always be via hoses. At operating pressures above 200 bar oil losses occur when the loading and unloading station are unloaded; this can be compensated for using an accumulator. The accumulator that is selected must have the appropriate safety equipment and comply with the safety regulation of the country concerned. We recommend the use of directional seat valves for controlling the rotary couplings.

6992H-21-06

6992H-21-08

6992H-21-10

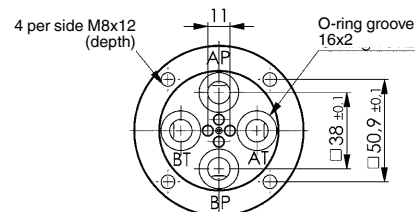
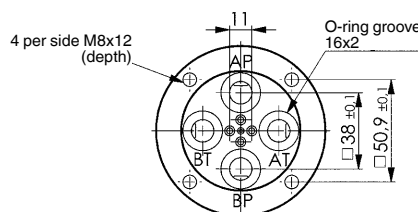
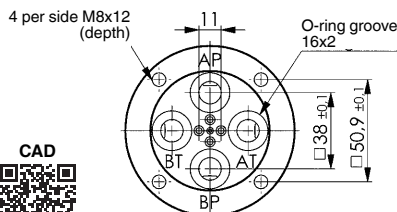
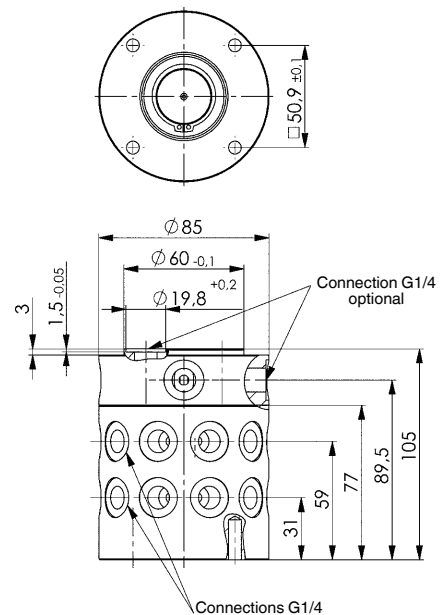
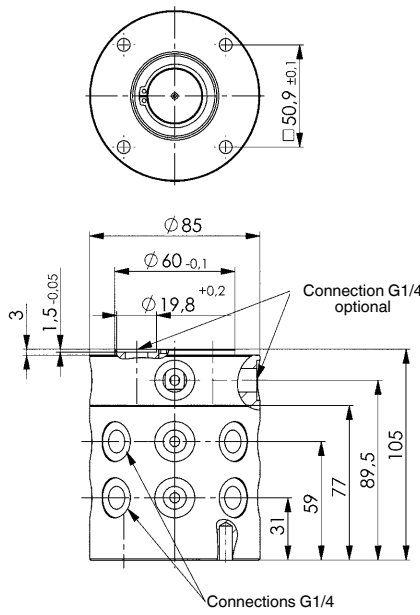
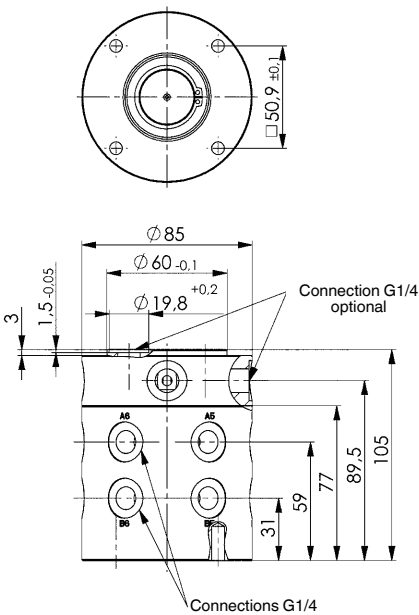

Subject to technical alterations.

Application example:

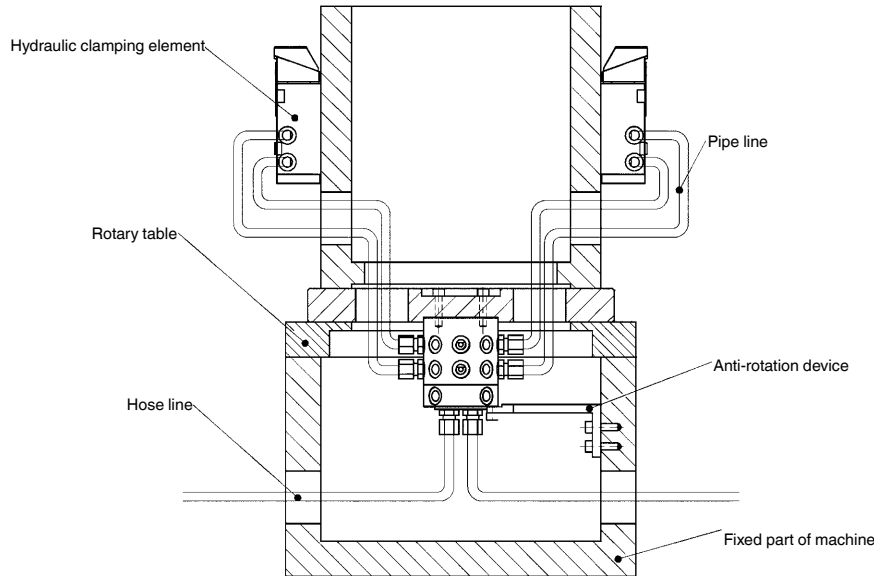

Example of schematic:

Rotary union double acting, controlled, 1 x loading, 7 x machining
 The loading and unloading station is controlled by a 4/3 way valve. The machining stations are directly controlled by the pump. The separation of loading and unloading station and machining stations by the rotary union is not leakagefree. Leakage increases with pressure. A pressure accumulator can be used for leakage compensation. The next cycle must only be performed when the loading or unloading station is clamped.

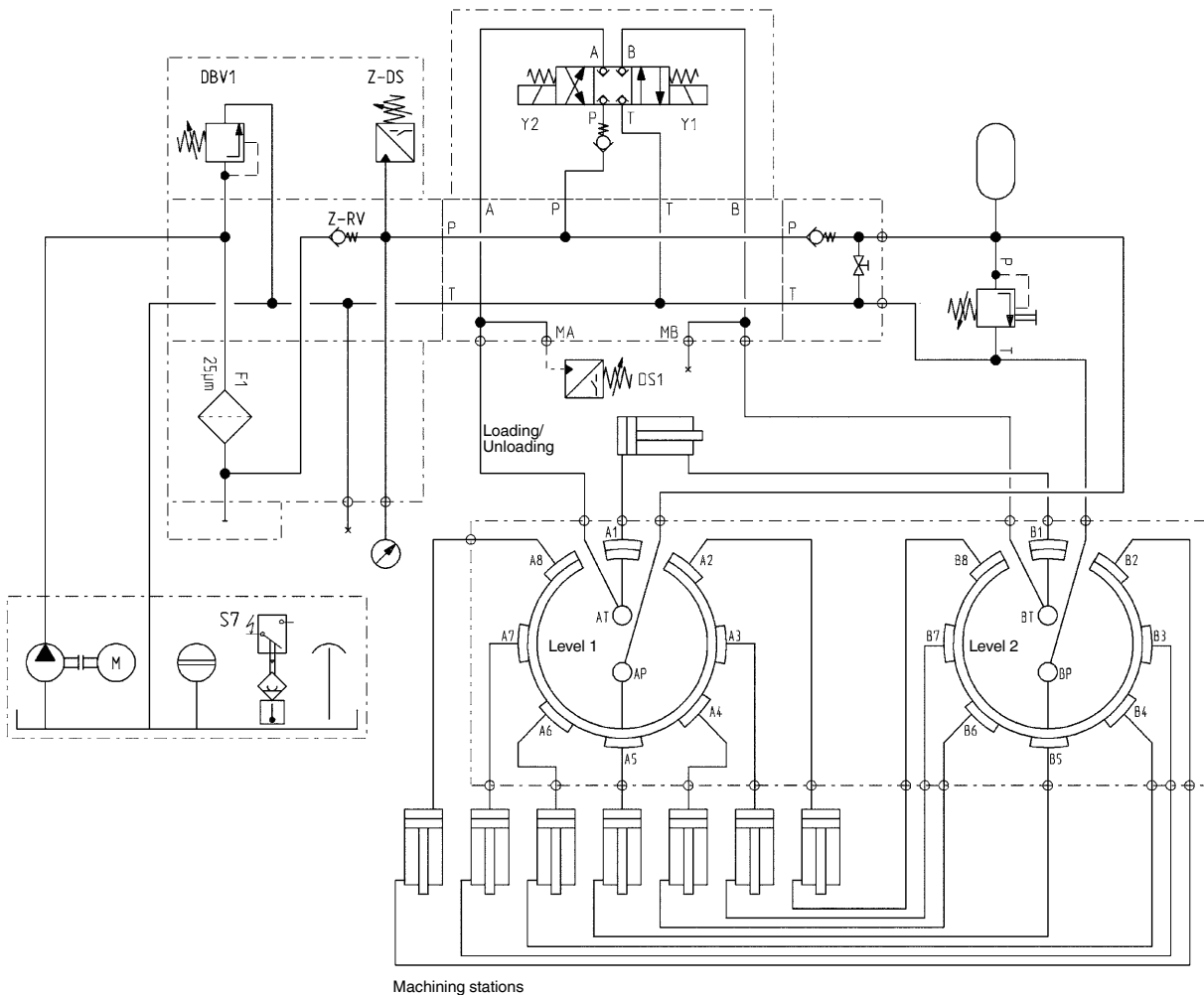

Subject to technical alterations.