

No. 6978CDA

Side clamping element with support

Double-acting,
max. operating pressure 250 bar,
min. operating pressure 30 bar.



CAD

Order no.	Article no.	Clamping force at 150 bar [kN]	Clamping force at 250 bar [kN]	Stroke	OR-1 O-ring Order No.	OR-2 O-ring Order No.	Weight [g]
562197	6978CDA-28	16,5	27,5	3	562537	562534	1250

Design:

Housing made of steel, burnished. Tension slide hardened. Alignment by cylinder pin. Integrated support control and grooved clamping jaw. Oil supply via oil channel in fixture body.

Application:

For clamping workpieces in a linear direction. Compact design thanks to integrated support and support control. A pneumatic support control is included as standard, which can be connected if required. The support height can be adjusted to the workpiece height by means of shims.

Features:

High flexibility through individually designed and exchangeable clamping jaws.

Note:

The installation hole must be free of burrs. Seals and housings must be greased during installation. Avoid chips from gathering via oil channels.

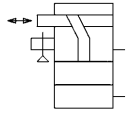

NEW!



Installation dimensions:

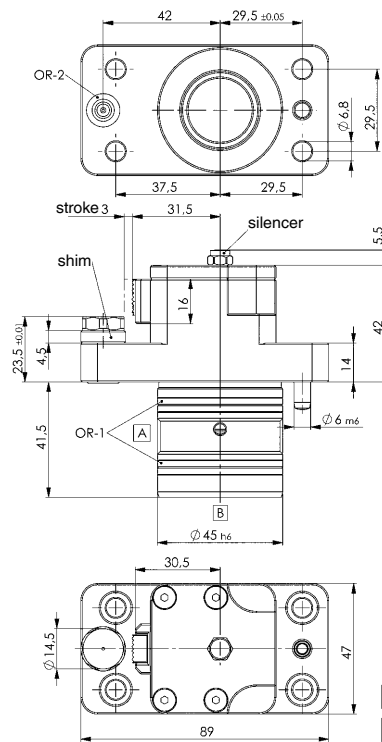
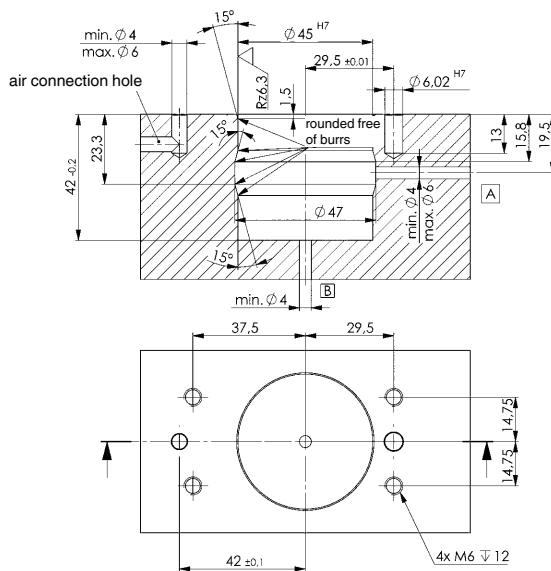

No. 6978CDA-28-06

Clamping jaws, serrated

NEW!



CAD

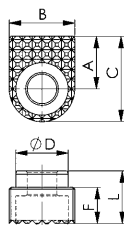

Order no.	Article no.	A	B	C	dia. D	F	L	Weight [g]
562201	6978CDA-28-06	8	10	13	8	5,5	8	4

Design:

Tempered steel, hardened and tempered, serrated clamping surface, with bolt.

Application:

For all workpieces with normal clamping faces.

No. 6978CDAR-28-06

Clamping jaws blank, smooth

NEW!



CAD

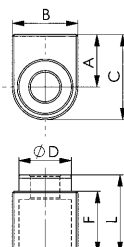
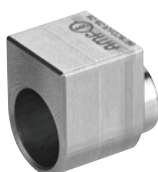

Order no.	Article no.	A	B	C	dia. D	F	L	Weight [g]
562202	6978CDAR-28-06	8	10	13	8	9,5	12	6,5

Design:

Tempered steel, unhardened, with smooth clamping surface, with bolt.

Application:

These clamping jaws can be shaped into any clamping form or ground flush for sensitive workpieces.

Subject to technical alterations.