

CK 500

Low Profile

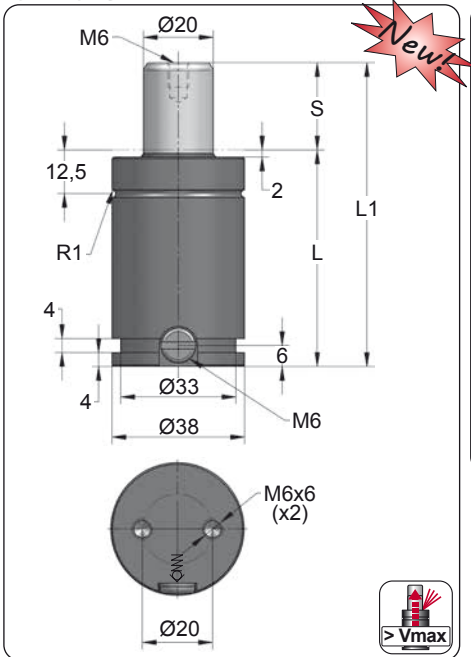



ORDER	S (mm)	L1 ±0,25 (mm)	L (mm)	Kg.
CK 500 010	10	57	47	0.29
CK 500 013	13	63	50	0.31
CK 500 016	16	69	53	0.32
CK 500 019	19	75	56	0.33
CK 500 025	25	87	62	0.36
CK 500 032	32	101	69	0.38
CK 500 038	38	113	75	0.41
CK 500 050	50	137	87	0.46
CK 500 063	63	163	100	0.51
CK 500 075	75	187	112	0.56
CK 500 080	80	197	117	0.58
CK 500 100	100	237	137	0.66
CK 500 125	125	287	162	0.76

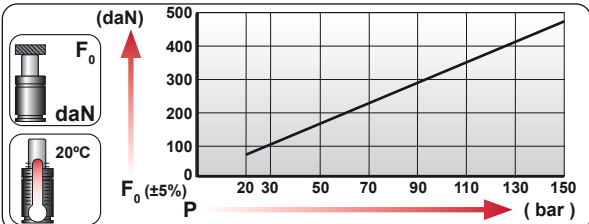

CODE				
	bar	psi	daN	daN
CK 500 050	150	2175	470	690
CK-H 500 050	0	0	---	---

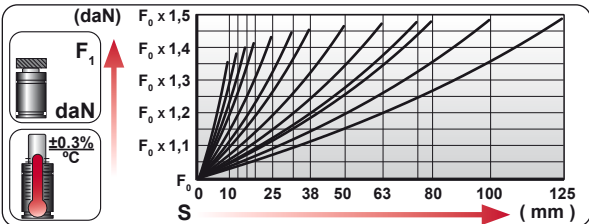

	ENG ORDER DEU BESTELLUNG FRA COMMANDE ITA ORDINE ESP PEDIDO POR PEDIDO		
		daN	mm
		500	50
		CK 500 050	

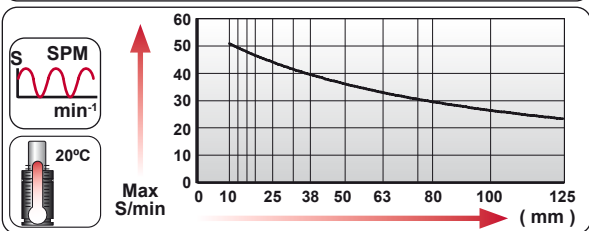

N ₂	S _{max} < 90%	V _{max} 1,6 m/s	P _{min} (20°C)	P _{max} (20°C)	T _{min}	T _{max}	600 CP-

bar	psi	bar	psi	°C	°F	°C	°F	
20	290	150	2175	0	32	80	176	

A14-038

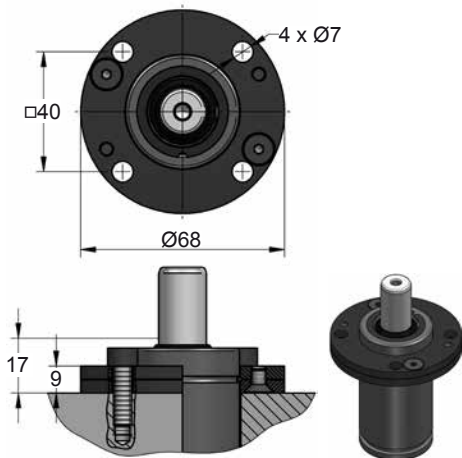

A34-038

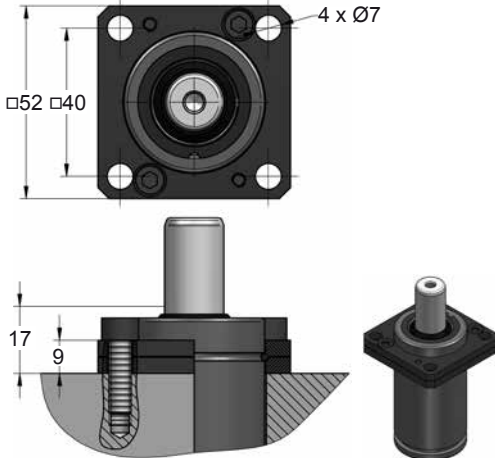

C20-038

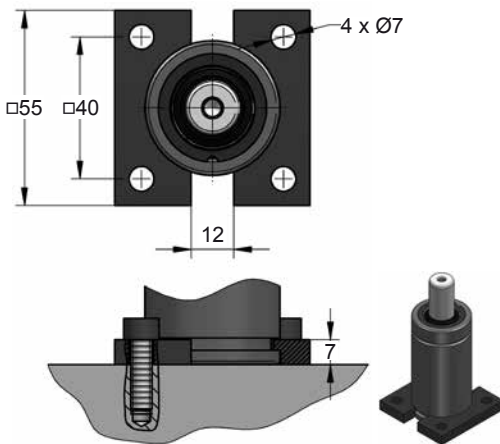

D67-038

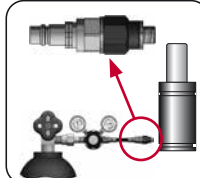
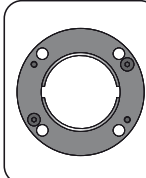
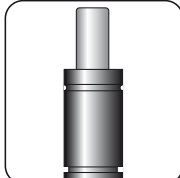
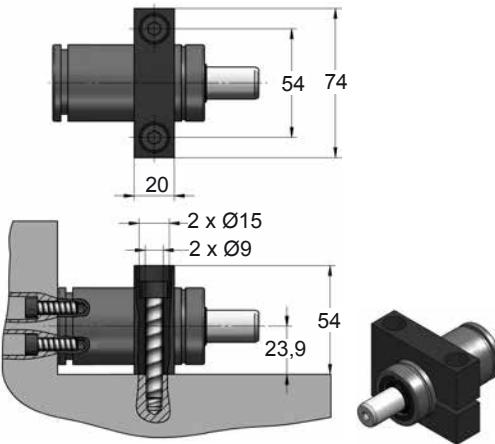

CODE	CK 500 050	KIT S-XXXXXXX KIT C-XXXXXXX	A14-038	06 CG 2-Q
ENG ORDER	GAS SPRING	REPAIR KIT	FLANGE	CHARGING ADAPTER
DEU BESTELLUNG	GASDRUCKFEDER	ERSATZTEILSATZ	FLANSCHEN	LADEADAPTER
FRA COMMANDE	RESSORT À GAZ	KIT DE RÉPARATION	BRIDE	RACCORD DE CHARGE
ITA ORDINE	CILINDRO AD AZOTO	KIT DI MANUTENZIONE	FLANGE	ADATTATORE DI CARICO
ESP PEDIDO	RESORTE DE GAS	KIT DE REPARACION	BRIDA	ADAPTADOR DE CARGA
POR PEDIDO	CILINDRO DE GÁS	KIT DE MANUTENÇÃO	FLANGE	ADAPTADOR DE CARGA