

VH 2200

Special Applications

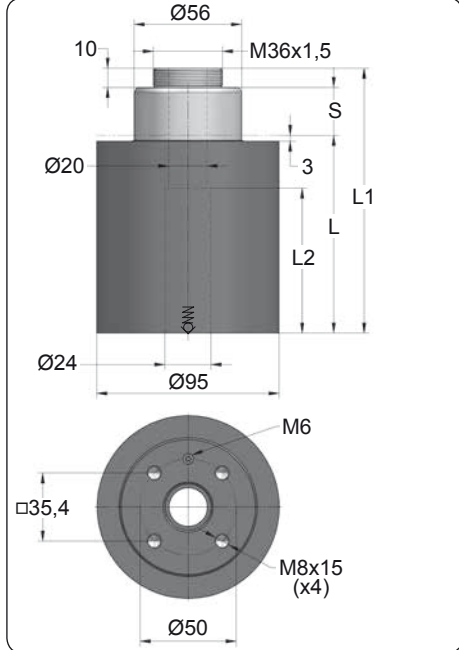

ORDER	S (mm)	L1 ±0,25 (mm)	L (mm)	L2 (mm)	Kg.
VH 2200 010	10	108	88	45.5	3.88
VH 2200 015	15	118	93	55.5	4.04
VH 2200 025	25	138	103	75.5	4.36
VH 2200 038	38	164	116	85.5	4.77
VH 2200 050	50	188	128	97.5	5.16
VH 2200 080	80	248	158	127.5	6.12
VH 2200 100	100	288	178	147.5	6.76

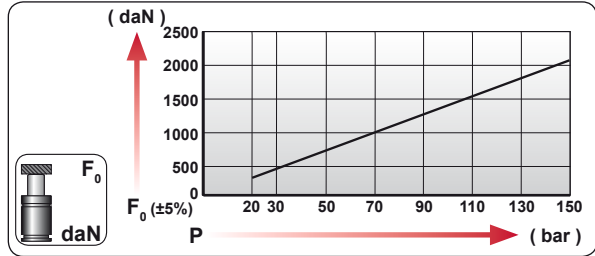

CODE				
		bar psi	daN	daN
VH 2200 050		150 2175	2168	3310
-----		-----	-----	-----

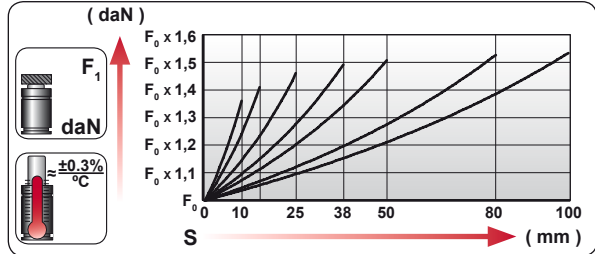

	ENG ORDER DEU BESTELLUNG FRA COMMANDE ITA ORDINE ESP PEDIDO POR PEDIDO		
		daN	mm
	VH 2200 50		
	VH 2200 050		

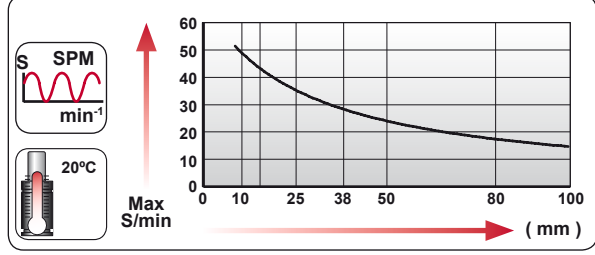

N ₂	S _{max} < 90%	V _{max} 0,5 m/s	P _{min} (20°C)	P _{max} (20°C)	T _{min}	T _{max}	

bar psi	bar psi	°C °F	°C °F	
20 290	150 2175	0 32	80 176	

B31-095

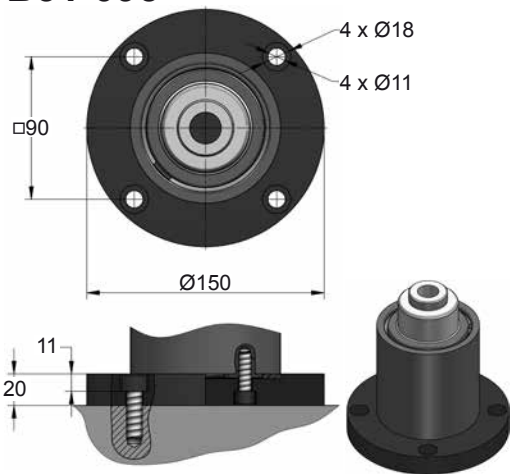

E33-095

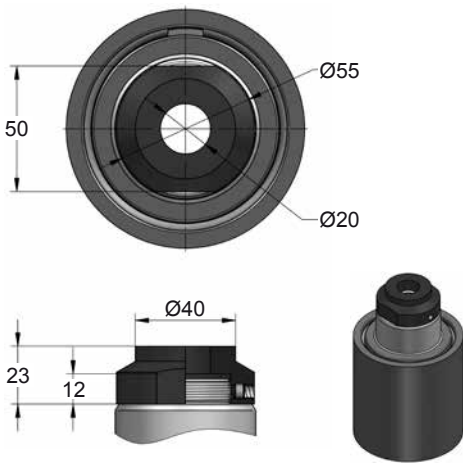

E33-095

VH 2200

B31-095

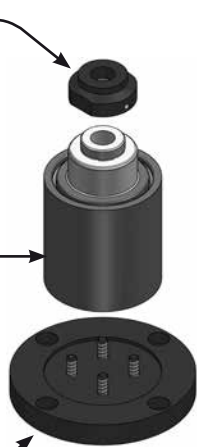

E33-095

VH 2200

B31-095

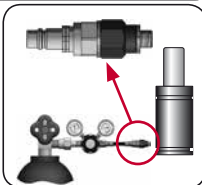
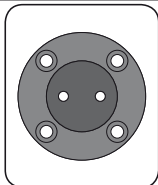
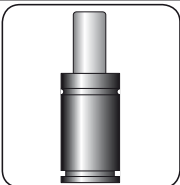

CODE	VH 2200 050	KIT S-XXXXXXX KIT C-XXXXXXX	B31-095	06 CG 2-Q
ENG	ORDER	GAS SPRING	REPAIR KIT	CHARGING ADAPTER
DEU	BESTELLUNG	GASDRUCKFEDER	ERSATZTEILSATZ	LADEADAPTER
FRA	COMMANDE	RESSORT À GAZ	KIT DE RÉPARATION	RACCORD DE CHARGE
ITA	ORDINE	CILINDRO AD AZOTO	KIT DI MANUTENZIONE	ADATTATORE DI CARICO
ESP	PEDIDO	RESORTE DE GAS	KIT DE REPARACION	ADAPTADOR DE CARGA
POR	PEDIDO	CILINDRO DE GÁS	KIT DE MANUTENÇÃO	ADAPTADOR DE CARGA