

PROJECTION WELD NUT M12

AIR-COOLED

Item number example for a complete electrode



for sheet hole diameter > 14.4 mm



Change electrode SW 30 > 1111-ZK-10206



Centring pin long, Cerazur > 8228-ZK-10114



Spring for BE up to 40 mm > 1112-ZK-12207



Base electrode standard Ø 28, 40 mm length > 1111-ZK-10521



O-ring > 1123-ZK-16436

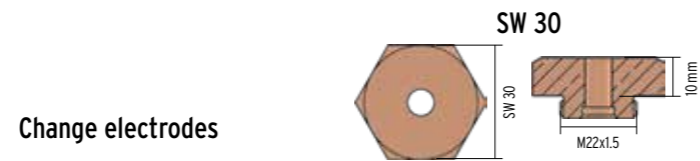

Change electrodes

Item No.	SW 30		SW 30		SW 30	
	1111-ZK-	1111-ZK-	1111-ZK-	1111-ZK-	1111-ZK-	1111-ZK-
13.0	10192	13.9	10201	14.8	10210	
13.1	10193	14.0	10202	14.9	10211	
13.2	10194	14.1	10203	15.0	10212	
13.3	10195	14.2	10204	15.1	10213	
13.4	10196	14.3	10205	15.2	10214	
13.5	10197	14.4	10206	15.3	10215	
13.6	10198	14.5	10207	15.4	10216	
13.7	10199	14.6	10208	15.5	10217	
13.8	10200	14.7	10209	-	-	

Centring pins

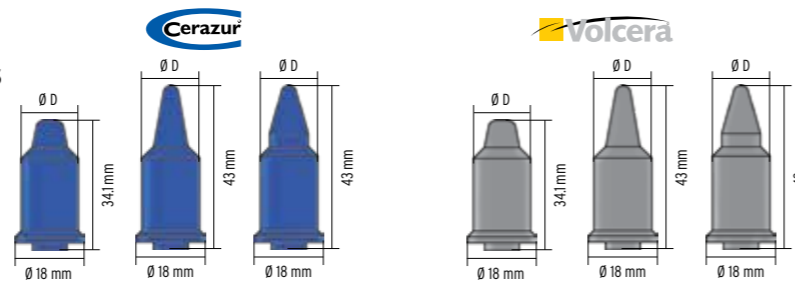

Item No.	Short			Long			With collar		
	8228-ZK-	8228-ZK-	8228-ZK-	8440-ZK-	8440-ZK-	8440-ZK-	8440-ZK-	8440-ZK-	8440-ZK-
13.0	11100	10100	10400	11100	10100	10400	11100	10100	10400
13.1	11101	10101	10401	11101	10101	10401	11101	10101	10401
13.2	11102	10102	10402	11102	10102	10402	11102	10102	10402
13.3	11103	10103	10403	11103	10103	10403	11103	10103	10403
13.4	11104	10104	10404	11104	10104	10404	11104	10104	10404
13.5	11105	10105	10405	11105	10105	10405	11105	10105	10405
13.6	11106	10106	10406	11106	10106	10406	11106	10106	10406
13.7	11107	10107	10407	11107	10107	10407	11107	10107	10407
13.8	11108	10108	10408	11108	10108	10408	11108	10108	10408
13.9	11109	10109	10409	11109	10109	10409	11109	10109	10409
14.0	11110	10110	10410	11110	10110	10410	11110	10110	10410
14.1	11111	10111	10411	11111	10111	10411	11111	10111	10411
14.2	11112	10112	10412	11112	10112	10412	11112	10112	10412
14.3	11113	10113	10413	11113	10113	10413	11113	10113	10413
14.4	11114	10114	10414	11114	10114	10414	11114	10114	10414
14.5	11115	10115	10415	11115	10115	10415	11115	10115	10415
14.6	11116	10116	10416	11116	10116	10416	11116	10116	10416
14.7	11117	10117	10417	11117	10117	10417	11117	10117	10417
14.8	11118	10118	10418	11118	10118	10418	11118	10118	10418
14.9	11119	10119	10419	11119	10119	10419	11119	10119	10419
15.0	11120	10120	10420	11120	10120	10420	11120	10120	10420

BASE ELECTRODES

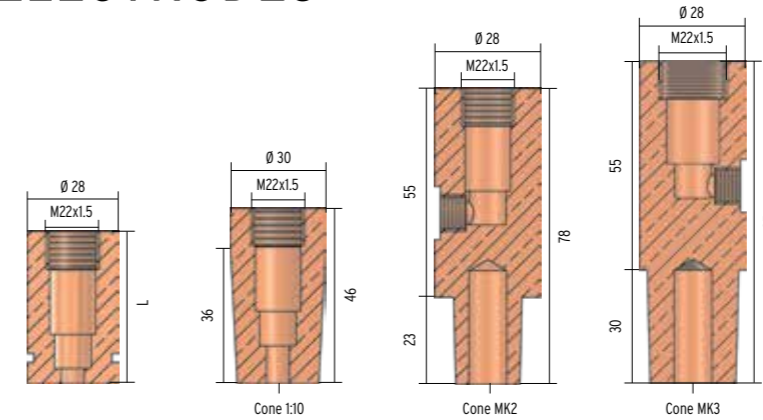

Length (L in mm)	Standard Ø 28		Cone 1:10		Cone MK2		Cone MK3	
	Item No.	1111-ZK-	1111-ZK-	1111-ZK-	1111-ZK-	1111-ZK-	1111-ZK-	1111-ZK-
40		10521	-	-	-	-	-	-
50		10522	-	-	-	-	-	-
60		10523	-	-	-	-	-	-
		-	10584	10546	10547			

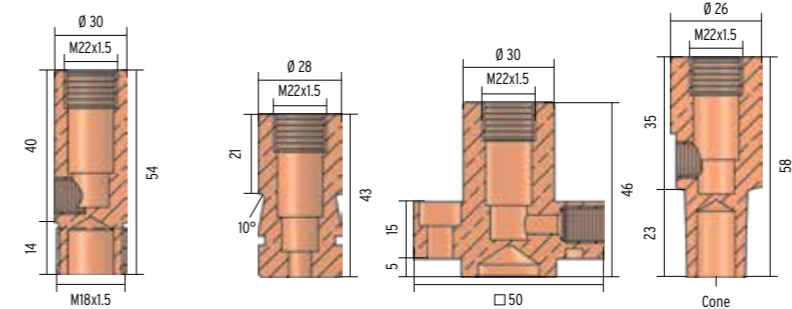

Item No.	Thread M18x1.5		S-type		R-type		T-type	
	1111-ZK-	1111-ZK-	1111-ZK-	1111-ZK-	1111-ZK-	1111-ZK-	1111-ZK-	1111-ZK-
	10564	10564	10684	10684	10622	10622	10646	10646

Accessories for base electrodes

Springs

For base electrodes from 40 mm

Length	Spring M12	
	Item No.	1112-ZK-
40 mm		12207

O-rings

Ø (mm)	O-rings M12	
	Item No.	1123-ZK-
28		16436
S-type		16436

Compressed air connector

Item No.	Compressed air connector 1/8-6	
	Item No.	1116-ZK-
		12353

Air-cooled complete electrode for projection nut welding

