

SÄULENGESTELL

201.36.

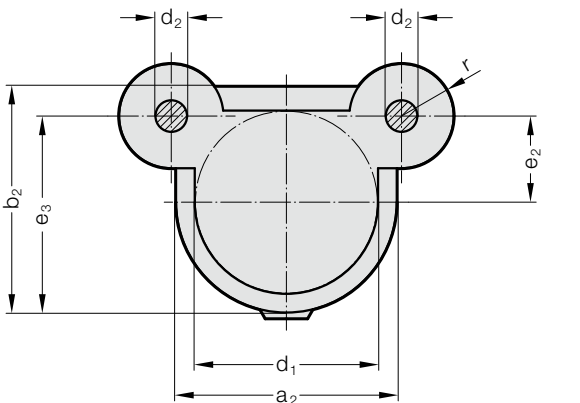
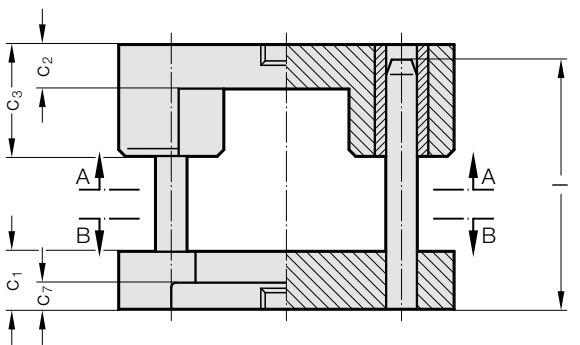
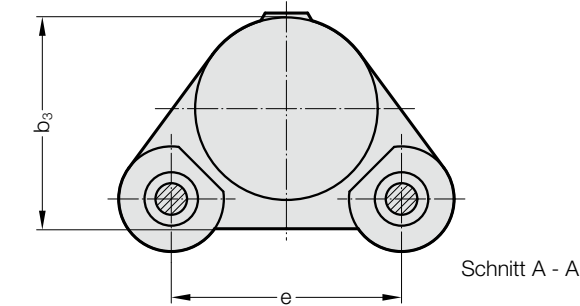

Führungsart

Sinterführung
carbonitriert

Kugelführung

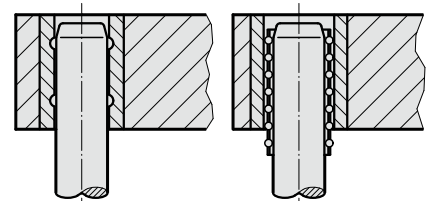

Bestell-Nr. Teil 2
Ohne Zapfengwinde
im Oberteil



201.36. Säulengestell

Bestell-Nummer Teil 1*	Arbeitsfläche													
	d ₁	a ₂	b ₂	b ₃	C ₁	C ₂	C ₃	C ₇	d ₂	e	e ₂	e ₃	l	r
201.36.050.□□□.□□	50	80	80	65	40	30	50	25	20	66	33	73	125 - 400	20
201.36.063.□□□.□□	63	94	94	78	45	30	60	25	20	82	41	88	125 - 400	25
201.36.080.□□□.□□	80	110	110	95	50	30	70	30	25	105	52	107	160 - 500	30
201.36.100.□□□.□□	100	140	140	120	50	30	70	30	25	125	57	127	160 - 500	30
201.36.125.□□□.□□	125	166	166	145	56	40	90	30	32	157	73	156	180 - 500	38
201.36.160.□□□.□□	160	200	200	180	63	50	120	30	40	200	85	185	224 - 800	48
201.36.180.□□□.□□	180	220	220	200	63	50	120	30	40	224	90	200	224 - 800	48
201.36.200.□□□.□□	200	250	250	225	63	50	120	30	50	250	95	220	224 - 800	56
201.36.250.□□□.□□	250	300	300	275	63	50	120	30	50	300	120	270	224 - 800	56

*Bestell-Nummer Teil 2 = Führungsart und Führungssäulen-Typ/-Länge ergänzen
 ☞ Bestell-Beispiel siehe Anfang des Kapitels A Guss-Säulengestelle