

弹顶销, 有硬度, 圆台阶 DIN 1530-2 C-TYP

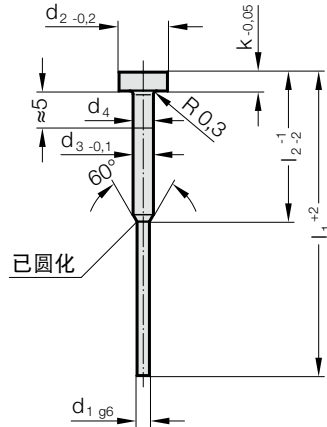

238.1.



材料:

WS

订购编号 238.1.

硬度:

杆部 60 ± 2 HRC

头部 45 ± 5 HRC

☞ 材料说明和其他材料见E章开头。

结构:

轴杆精密打磨, 硬化。

头部顶锻并回火。

头部下方顶锻加粗

取消, 依据制造商操作程序。

d₄: 对于 d₃ < 5 mm, d₄ = d₃+0.03

对于 d₃ ≥ 5 mm, d₄ = d₃+0.04

对于 d₃ ≥ 18 mm, d₄ = d₃+0.07

238.1. 弹顶销, 有硬度, 圆台阶 DIN 1530-2 C-Typ

d ₁	d ₂	d ₃	k	l ₁	63	80	100	125	160	200
					30	32	50	50	63	80
0.8	4	2	2		●	●	●	●	●	
0.9	4	2	2		●	●	●	●	●	
1	4	2	2		●	●	●	●	●	●
1.1	4	2	2		●	●	●	●	●	●
1.2	4	2	2		●	●	●	●	●	●
1.3	4	2	2		●	●	●	●	●	●
1.4	4	2	2		●	●	●	●	●	●
1.5	6	3	3		●	●	●	●	●	●
1.6	6	3	3			●	●	●	●	●
1.7	6	3	3			●	●	●	●	●
1.8	6	3	3			●	●	●	●	●
1.9	6	3	3			●	●	●	●	●
2	6	3	3			●	●	●	●	●
2.1	6	3	3				●	●	●	●
2.2	6	3	3				●	●	●	●
2.3	6	3	3				●	●	●	●
2.4	6	3	3				●	●	●	●
2.5	6	3	3				●	●	●	●

订购示例:

弹顶销, 有硬度, 圆台阶 DIN 1530-2 C-Typ =238.1.

直径 d₁ 1.7 mm = 0170.

长度 l₁ 80 mm = 080

订购编号 =238.1. 0170. 080