

CENTERING UNIT

CENTERING UNIT, FLAT

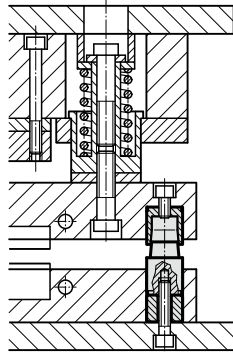

Mounting example



2442.12.

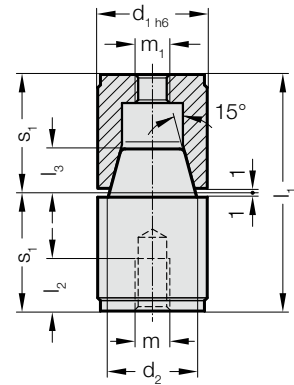

Description:

Conical centring units are used to increase repeat accuracy in mould, die and machine-making.

2442.12. Centering unit

Order No	d ₁	d ₂	l ₁	l ₂	l ₃	m, m ₁	s ₁
2442.12.012.034	12	8	34	6	4	M4	17
2442.12.014.034	14	10	34	7.5	6	M5	17
2442.12.016.034	16	10	34	7.5	6	M5	17
2442.12.020.054	20	15	54	12	9	M8	27
2442.12.025.054	25	20	54	12	10	M8	27
2442.12.026.054	26	20	54	12	10	M8	27
2442.12.030.072	30	25	72	15	14	M10	36
2442.12.032.072	32	25	72	15	14	M10	36
2442.12.042.092	42	35	92	15	18	M10	46



2442.13.

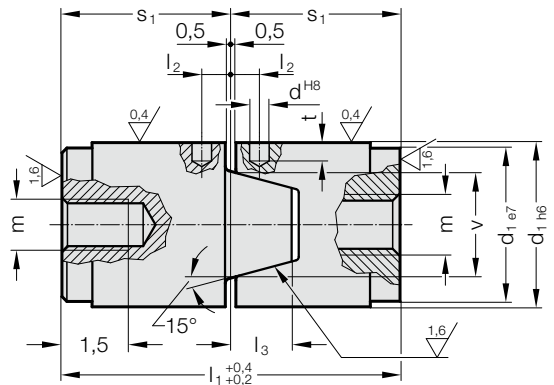

2442.13. Centering unit, flat

Order No	d ₁	d	l ₁	l ₂	l ₃	v	s ₁	t	m
2442.13.030.072	30	4	72	5	10	18	36	5	M10
2442.13.042.092	42	5	92	6	14	23	46	7	M10
2442.13.054.112	54	6	112	8	17	30	56	8	M12
2442.13.080.152	80	8	152	8	27	42	76	11	M16