

# OVERRUN CAM, BRONZE WITH SOLID LUBRICANT, VDI 3357

2960.92.

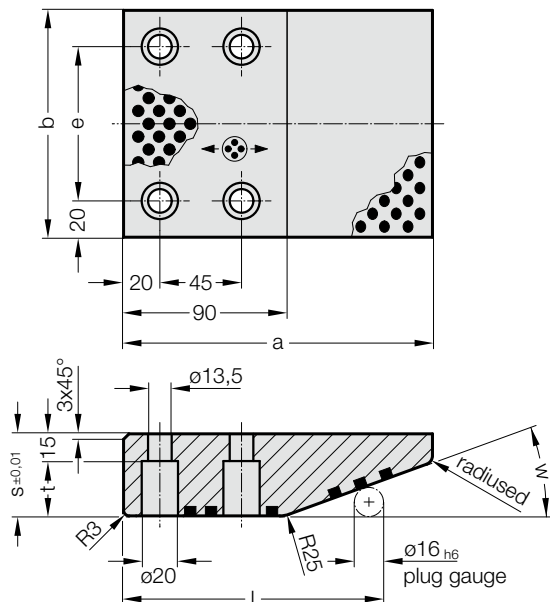

Mounting example

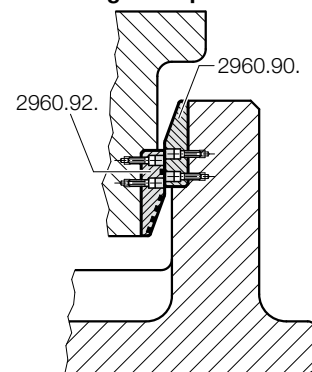

## 2960.92. Overrun Cam, Bronze with solid lubricant, VDI 3357

Order No	b	a	s	e	t	w	l
2960.92.100.170.045	100	170	45	60	30	20	143.37
2960.92.125.170.045	125	170	45	85	30	20	143.37
2960.92.150.170.045	150	170	45	110	30	20	143.37
2960.92.200.170.045	200	170	45	160	30	20	143.37
2960.92.100.150.045	100	150	45	60	30	30	127.86
2960.92.100.170.060	100	170	60	60	45	30	127.86
2960.92.125.150.045	125	150	45	85	30	30	127.86
2960.92.125.170.060	125	170	60	85	45	30	127.86
2960.92.150.150.045	150	150	45	110	30	30	127.86
2960.92.150.170.060	150	170	60	110	45	30	127.86
2960.92.200.150.045	200	150	45	160	30	30	127.86
2960.92.200.170.060	200	170	60	160	45	30	127.86

### Material:

Bronze with solid lubricant, oilless lubricating

### Note:

Screws are not included.

### Fixing:

Use socket cap screws  
DIN EN ISO 4762 M12.