

Überlastkupplung

mit zwei Außenkonen

optional
chem. vernickelt
optional komplett
in Edelstahl

optional
lasergeschweißt

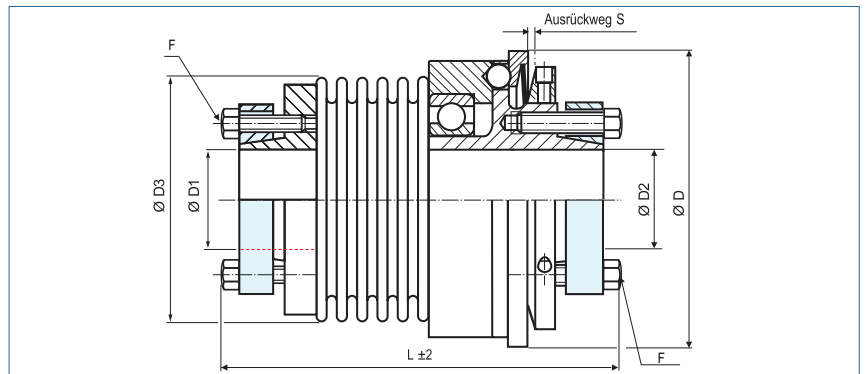

Bestellbeispiel **KBK/BAA - 60 - 108 - 15H7 - 18H7 - 20Nm - C oder D - 2**

Typ Größe Länge ØD1 (H7) ØD2 (H7) Auslösemoment Überlastbereich
C = Synchronschaltung D = Durchratschaltung

Größe	Abmessungen (mm)							Technische Daten										
	ØD	L	ØD1	ØD2	ØD3	F	S	Maximaldrehzahl (1/min)	Masse (kg)	Massentätigkeitsmoment J (kg cm ²)	Überlastbereich		Federsteifigkeit			zulässiger Versatz		
	Außen-durchmesser	Länge	Bohrung (H7) von-bis	Bohrung (H7) von-bis	Schraube ISO4017 TA (Nm)	1 TKN (Nm)	2 TKN (Nm)				Torsion x10 ³ CT (Nm/rad)	radial CR (N/mm)	axial CA (N/mm)	radial Δ Kr (mm)	axial Δ Ka (mm)	Winkel Δ Kw (°)		
-10	49	66	5-14	5-14	40.5	M3	0.7	11650	0.27	0.6	3 - 7	5 - 10	8.1	120	27	0.15	0.4	1.5
		75	10#	10#		2.1							6.8	29	17	0.3	0.6	2
-30	64	78	12-20	12-20	56	M5	1.2	9540	0.74	3.0	5 - 15	10 - 30	38	720	50	0.15	0.6	1.5
		87	14#	14#		5.9							28	225	28	0.25	1	2
-60	79	97	15-32	15-30	66	M5	1.2	8180	1.41	8.6	12 - 35	20 - 60	75	1150	90	0.15	0.6	1.5
		108	24#	22#		8.7							50	340	50	0.25	1	2
-80	94	116	20-35	20-35	82	M6	2	6220	2.6	23	15 - 40	30 - 80	128	1200	80	0.2	0.5	1.5
		129	27#	27#		15							75	400	50	0.25	0.8	2
-150	94	116	20-35	20-35	82	M6	2	6220	2.6	23	50 - 130	65 - 150	155	2020	145	0.2	0.5	1.5
		129	27#	27#		15							105	595	85	0.25	0.8	2
-200	109	118	20-42	20-42	90	M6	2	5720	2.9	35	30 - 90	80 - 200	175	2500	147	0.2	0.5	1.5
		132	34#	34#		15							116	460	82	0.25	0.8	2
-300	119	141	25-50	25-50	110	M8	2	5200	4.6	70	60 - 200	150 - 300	502	6300	280	0.2	0.5	1.5
		152	41#	41#		25							285	1400	145	0.25	0.8	2
-500	129	159	35-55	35-55	122	M8	2	4470	6.8	121	80 - 250	200 - 500	690	7790	100	0.2	0.5	1.5
		171	45#	45#		36							320	970	85	0.25	1	2
-800	169	250	50-70	50-70	157	M12	2	3350	17.7	514	240 - 600	500 - 800	700	500	185	0.2	0.8	1.8
			58#	58#		85												
-1400	169	250	50-70	50-70	157	M12	2	3350	17.8	516	360 - 1000	900 - 1400	1270	700	275	0.2	0.8	1.8
			58#	58#		115												

Material	Außenkonus - Stahl Balg - Edelstahl
Passfedernut	wahlweise nach DIN 6885 größtmögliche Bohrung mit # gekennzeichnet
Temperaturbereich	-30 °C ~ 120 °C