

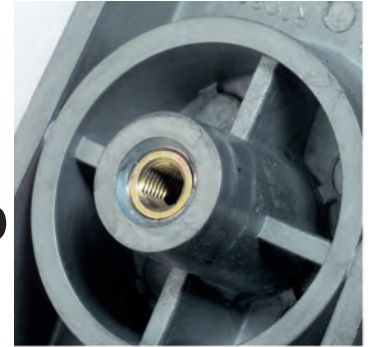

The Ensats® – pull-out resistance due to flange cover ...



Connections using threaded insert Ensats® permit substantially smaller dimensions and consequently material and weight-saving designs.

The illustration below (Fig. 2) shows a screw connection with different screw cross-sections. Despite the smaller

screw cross-section, a screw joint with an Ensats® is capable of withstanding higher axial forces than the screw joint with larger screw cross-section; because the force – both under static and dynamic load – in the Ensats® male thread is distributed evenly over the individual thread turns of the Ensats® male thread.

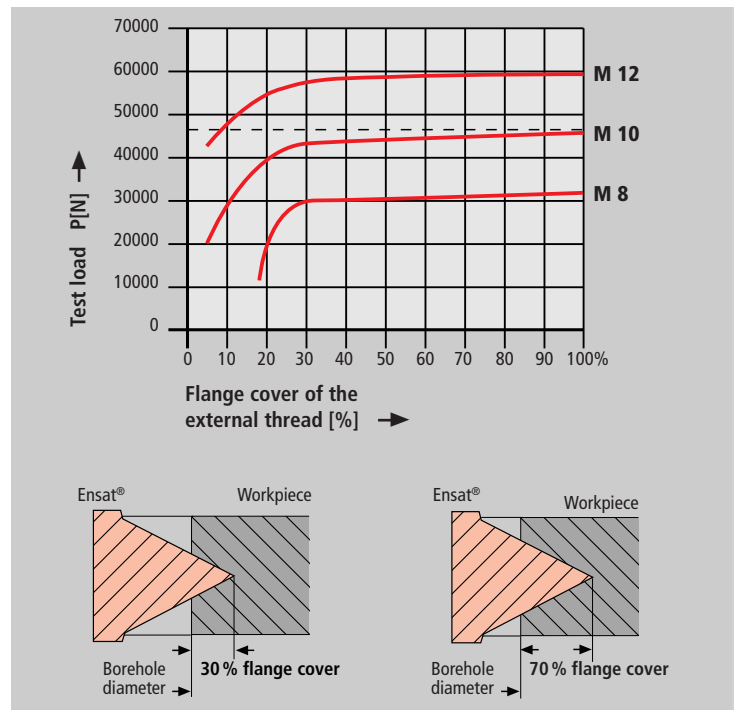

Fig. 3

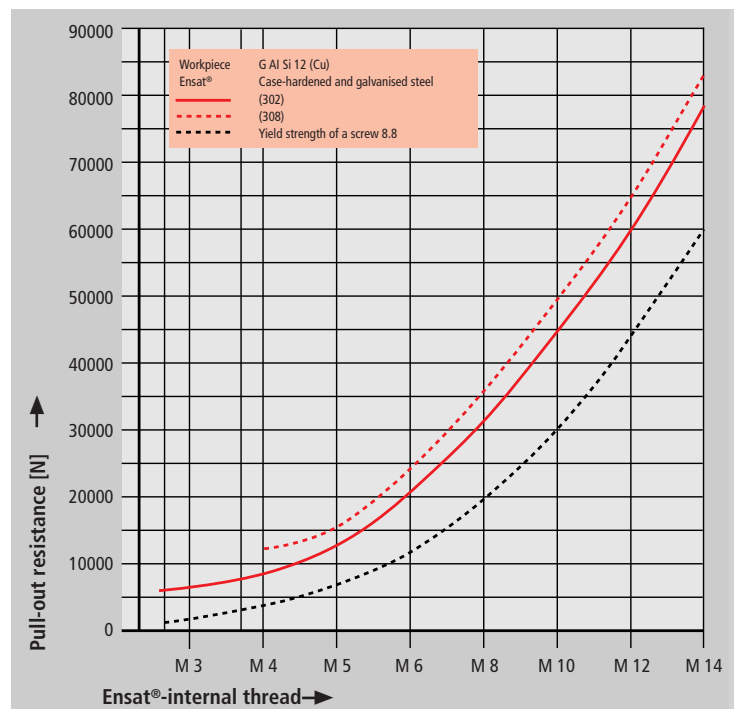
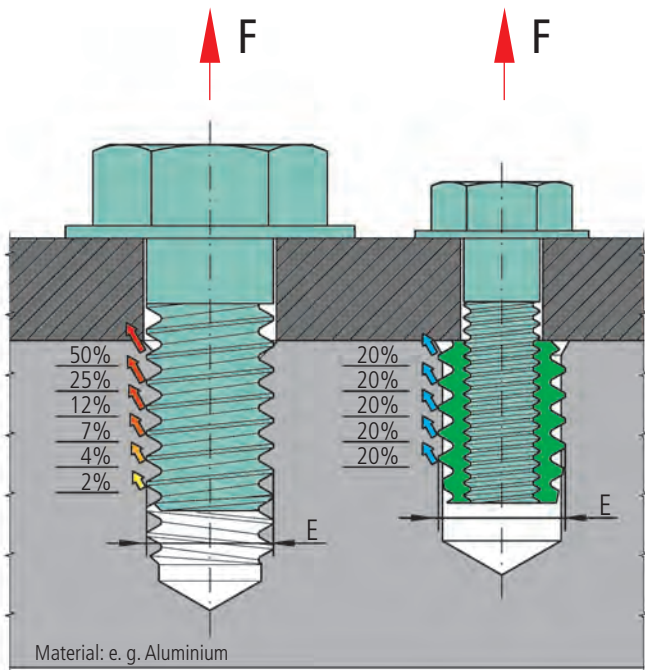

Fig. 4



E = Diameter cut thread = Outside diameter of the Ensats®

Fig. 2

Flange cover

In a workpiece made of a light alloy, the Ensats® 302 achieves almost maximum pull-out strength with only 30% flange cover (Fig. 3).

Pull-out strength

The Ensats® is capable of withstanding high loads. When used in light alloys, for example, a degree of pull-out strength is achieved which far exceeds the yield strength of the mating screw 8.8 (Fig. 4).





Threaded insert
self-tapping / with hexagonal socket

Ensat®-SBKI
Works Standard
307 3 and 308 3

Application

The Threaded insert Ensat®-SBKI based on the part geometry of the threaded insert Ensat®-SB.

The head serves as a support for electrical contacts when fastening several parts simultaneously; when stress is applied against the head, the pull-through force is significantly increased.

Hexagonal socket

The Ensat® is inserted via the hexagonal socket, permitting the achievement of short installation time.

Weitere Vorteile: einfachere Ein
Other benefits: More simple driving tools and machines which require only clockwise rotation.

The Ensat® can be extracted without problems before the recycling process, resulting in lower costs.

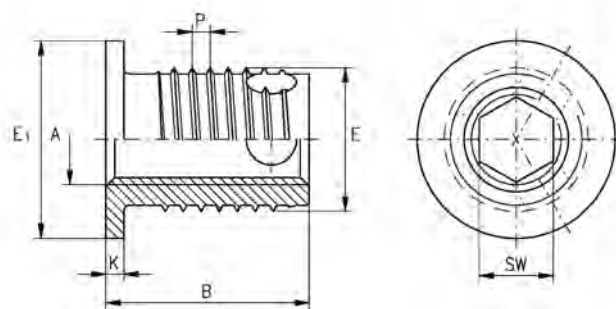

Dimensions in mm

Article number	Internal thread	External thread Special thread		Head diameter	Head height	Length	Hexagonal socket	Guideline values for receiving hole diameter	Minimum borehole depth for blind holes
	A	E	P	E ₁	K		B	SW +0,1	L
307 300 050 ...	M 5	8	1	11	1	8	4,1	7,6 to 7,7	9
308 300 050 ...	M 5	8	1	11	1	11	4,1	7,6 to 7,7	13
307 300 060 ...	M 6	10	1,25	13	1,5	9,5	4,9	9,5 to 9,6	10
308 300 060 ...	M 6	10	1,25	13	1,5	13,5	4,9	9,5 to 9,6	15
307 300 080 ...	M 8	12	1,5	15	1,5	10,5	6,6	11,3 to 11,5	11
308 300 080 ...	M 8	12	1,5	15	1,5	15,5	6,6	11,3 to 11,5	17
307 300 100 ...	M 10	14	1,5	17	1,5	11,5	8,3	13,3 to 13,5	13
308 300 100 ...	M 10	14	1,5	17	1,5	19,5	8,3	13,3 to 13,5	22

Example for finding the article number

Self-tapping threaded insert hexagonal socket Ensat®-SBKI to Works Standard 307 3 with internal thread A = M5 made of case-hardened, zinc plated and blue passivated steel: Ensat®-SBKI 307 300 050.110

Short design
Long design

Works Standard 307
Works Standard 308

Materials

Case-hardened steel, zinc plated, blue passivated
Case-hardened steel, zinc-nickel plated, transparent passivated
Brass

Article no. (**fourth** group of digits) 110
Article no. (**fourth** group of digits) 143
Article no. (**fourth** group of digits) 800

Other materials, designs and finishes on request.

Tolerance

ISO 2768-m

Thread

Internal thread A: as per ISO 6H
External thread E: Special thread with flattened thread root, as per KKV standard