

Ensat® – driving tools...

On this page, you can configure the optimum tool for your application. A configuration is provided in the following as an illustrative example.

The article number is composed of two sequences of numbers and starts with the tool shank (fig. 8) which should be selected in accordance with your output.

Also encrypted in this number are the special versions for thin-walled Ensat® (620 1 and 621 1) and for very high driving torques (622 0 and 623 0) which are available as standard only as a square shank. Other non-standard geometries can be evaluated as standard besides the tools illustrated. The second sequence of numbers in the table (fig. 9) indicates the thread code of the female thread. The tightened dimensions of the tools are shown on the next page.

Tool for accessible retaining boreholes (short)

- 1 Shank
- 4 Stop pin
- 9 Ball
- 5 Fixing screw
- 6 Ball bearing
- 2 Shell
- 3 Guide bush
- 7 Stud

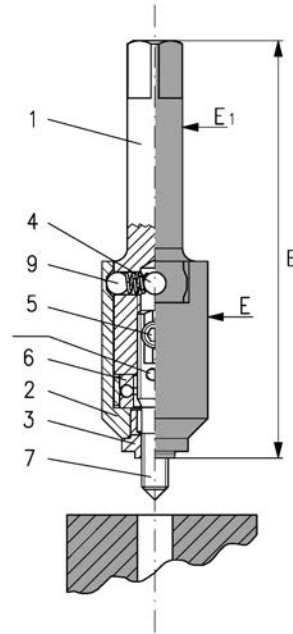

Tool for deep located retaining boreholes (long)

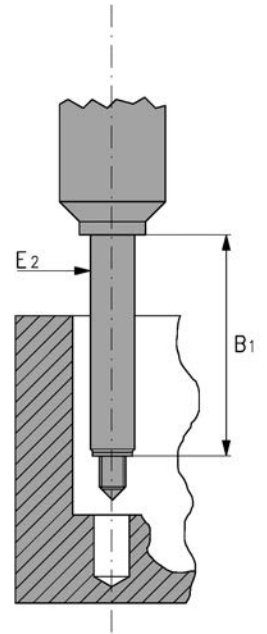

Fig. 6

The right length of the threaded pin for the Ensat® with cutting slot or with cutting bore is calculated from the pitch of the female thread (see also Fig. below; P = pitch of the female thread).

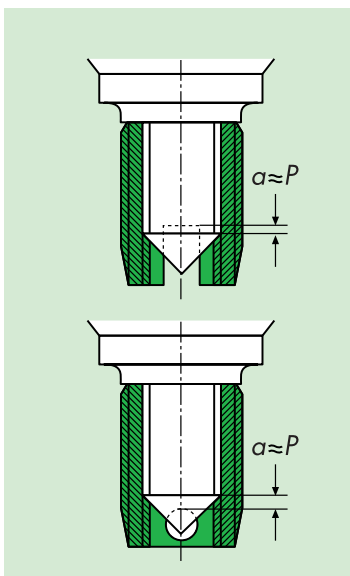

Fig. 7

Setting or exchanging the stud

- Pull the shell (2) downwards off the shank (1).
- Release the locking screws (5).
- Screw the stud (7) in or out. Yellow colour marking indicates flattened surfaces for the locking screws.
- When assembling, tighten both screws (5) evenly.
- Insert the ball bearing (6).
- Push on the shell (2) until the ball stop locks into place. For the tool to function perfectly, the shell must be very easy to rotate. Shorten the thread of tool 610 accordingly for short Ensat®.
- Unscrew the guide bush (3) at the front if the Ensat® is to be installed deeper than 0.2 mm under the surface of the workpiece. Diameter: 0.1 to 0.2 mm smaller than Ensat® retaining hole.

For mounting thin-walled Ensat® (page 17), special guide bushes must be used (tools 620 1 and 621 1).

Conditions for flawless tool function

- Locking and unlocking the tool on the Ensat® surface is guaranteed by a thrust bearing (6).
- The stop pins (4) execute the impact at the shell (2) which unlocks the tool.
- Wear at the stud (7) can result in unlocking problems.

The components are also offered as single parts to allow you to carry out your own repairs to the tool.

Simply give us a call.

Ensat® – driving tools...



Example:

You wish to insert an Ensat® 308 000 050. 110. For the installation process, you have selected a driving tool with spindle hexagon socket to DIN ISO 1173 and have to mount the insert into a deep positioned borehole.

Shank:

636 0...
(long for deep positioned borehole)

Thread code:

...00 050...
(for thread M5)

Suffix numbers:

.... 000
(with always the same tools)

Order no: **636 000 050.000**

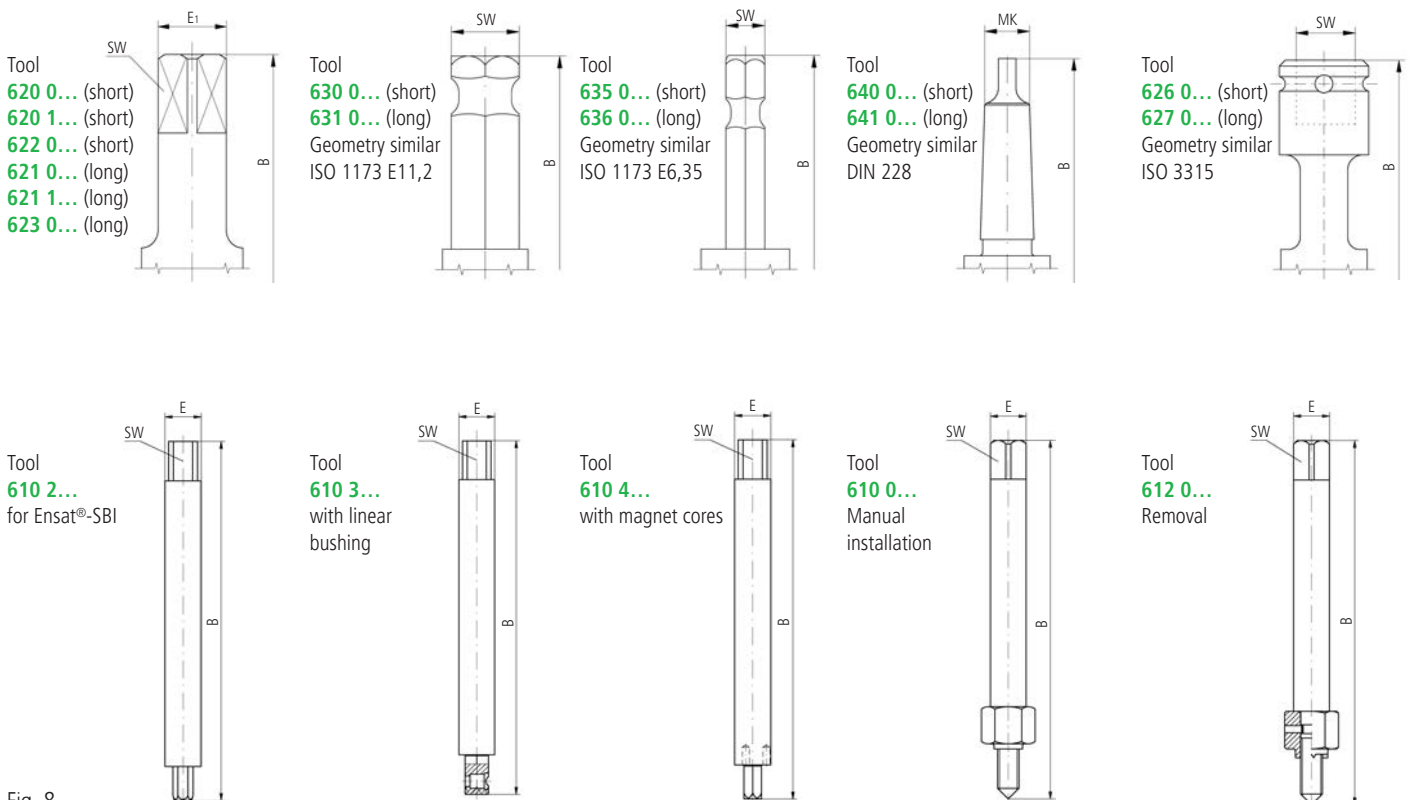

Fig. 8

Artikel-No.	For Ensaf®	M 2	M 2,5	M 3	M 3,5	M 4	M 5	M 6	M 8	M 10	M 12	M 14	M 16	M 18	M 20	M 22	M 24	M 27	M 30	
	Metrisch	...00 020.000	...00 025.000	...00 030.000	...00 035.000	...00 040.000	...00 050.000	...00 060.000	...00 080.000	...00 100.000	...00 120.000	...00 140.000	...00 160.000	...00 180.000	...00 200.000	...00 220.000	...00 240.000	...00 270.000	...00 300.000	
	Whitworth	—	—	—	—	—	—	...00 525.000	...00 531.000	...00 537.000	...00 544.000	...00 550.000	...00 562.000	—	—	—	—	—	—	
	UNC	—	—	...00 604.000	...00 606.000	...00 608.000	...00 610.000	...00 625.000	...00 631.000	...00 637.000	...00 644.000	...00 650.000	...00 662.000	—	—	—	—	—	—	
	UNF	—	—	...00 704.000	...00 706.000	...00 708.000	...00 710.000	...00 725.000	...00 731.000	...00 737.000	...00 744.000	...00 750.000	...00 762.000	—	—	—	—	—	—	
Measurement table																				
Tool type 620 0... (short version), 620 1... (variant for thin-walled-ENSAT®) and 621 0... (long version), 621 1... (variant for thin-walled-ENSAT®)																				
E ₁		8	8	8	8	8	12,5	12,5	12,5	16	16	25	25	25	25	25	30	30	30	
SW		6,3	6,3	6,3	6,3	6,3	10	10	10	12,5	12,5	20	20	20	20	20	25	25	25	
B		78	78	78	78	78	95	95	95	118	118	145	145	145	169	169	198	198	198	
B ₁		40	40	40	40	40	50	50	50	60	60	60	60	60	60	60	60	60	60	
E		18	18	18	18	18	24	24	24	32	32	50	50	50	58	58	70	70	70	
E ₂		7	7	7	7	7	9	10	12	15	18	20	22	24	26	28	32	35	38	
Tool type 622 0... (short version, reinforced version for high installation torques) and 623 0... (long version, reinforced version for high installation torques)																				
E		○	○	○	○	○	36	36	36	43	43	○	○	○	○	○	○	○	○	
Tool type 630 0... (short version, hexagonal shaft) and 631 0... (long version hexagonal shaft)																				
SW		11,11	11,11	11,11	11,11	11,11	11,11	11,11	11,11	11,11	11,11	11,11	11,11	11,11	—	—	—	—	—	
B		71	71	71	71	71	83	83	83	98	98	118	118	118	—	—	—	—	—	
Tool type 635 0... (short version, hexagonal shaft) and 636 0... (long version, hexagonal shaft)																				
SW		6,35	6,35	6,35	6,35	6,35	6,35	6,35	6,35	6,35	6,35	—	—	—	—	—	—	—	—	
B		66	66	66	66	66	78	78	78	93	93	—	—	—	—	—	—	—	—	
Tool type 640 0... (short version, morse taper shaft) and 641 0... (long version, morse taper shaft)																				
MK	MK0	MK0	MK0	MK0	MK0	MK0	MK2	MK2	MK2	MK3	MK3	MK4	MK4	MK4	MK4	MK4	MK4	MK4	MK4	
B		○	○	○	○	○	○	○	○	○	176,5	○	222,5	○	○	○	○	○	○	
Tool type 626 0... (short version, square socket shank) and 627 0... (long version, square socket shank)																				
SW		—	—	—	—	—	1/2"	1/2"	1/2"	1/2"	1/2"	1/2"	1/2"	1/2"	1/2"	1/2"	1/2"	1/2"	1/2"	
B		—	—	—	—	—	94,5	94,5	94,5	117,5	117,5	140,5	140,5	140,5	168,5	168,5	197,5	197,5	197,5	
Tool type 610 2..., 610 3... (from M 8), 610 4... (from M 6) – (for ENSAT® with hexagon socket)																				
E		—	—	—	—	—	8	10	10	12	14	16	18	—	—	—	—	—	—	
B		—	—	—	—	—	90	100	100	110	125	125	125	—	—	—	—	—	—	
SW		—	—	—	—	—	6,2	8	8	9	11	12	15	—	—	—	—	—	—	
Tool type 610 0..., 612 0... (manual driving tools)																				
E		—	6	6	6	6	10	10	10	16	16	16	—	—	—	—	—	—	—	
B		—	55	55	60	60	75	75	75	95	95	95	—	—	—	—	—	—	—	
SW		—	5	5	5	5	8	8	8	12,5	12,5	12,5	—	—	—	—	—	—	—	

In order to obtain the length dimension of the extended tool versions, the specified dimensions B must be added in each case to the dimension B1.

○ = available on request

Manual Ensats[®] - installation ...

Manual installation with driving tool and tap wrench:

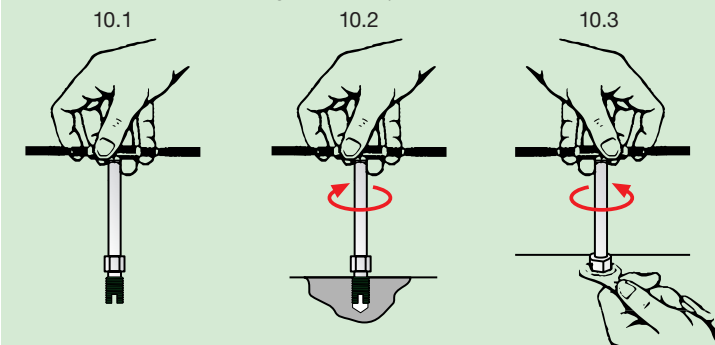

Fig. 10

Emergency installation using screw and nut:

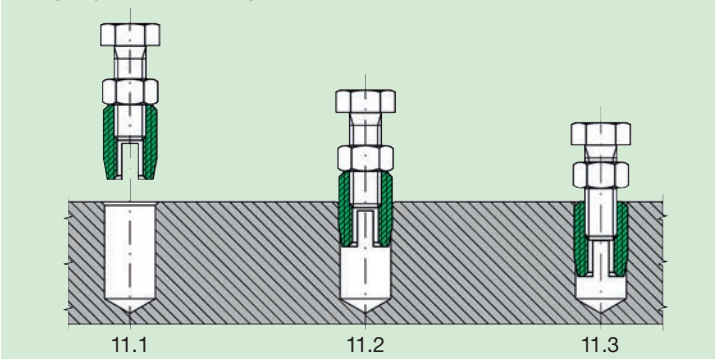

Fig. 11

Manual Insertion Process

The manual insertion is usually carried out using the manual tool 610 0 ... via the female thread or in the case of the tools 610 2 ... using the hexagon socket. You can of course also use power tools for the manual assembly. If doing so, it needs to be ensured that the rotatable sleeve (2, see fig. 6) is in the corresponding correct position (see fig. 15 procedure description).

Image 10.1/11.1

Thread the Ensats[®], cutting geometry (slit or bore) has to be pointing downward. Attention needs to be paid while doing so that the screw with nut does not face in the direction of the cutting geometry after locking with a counter nut, as the shavings are otherwise not discharged.

Image 10.2/11.2

Screw in the Ensats[®] until approx. 0.1-0.2 mm underneath the surface of the work piece like in image 4 (during temporary assembly using screw and nut, the Ensats[®] should be processed until flat). Vertical assembly must be ensured.

Image 10.3/11.3

Loosen the counter nut, otherwise the Ensats[®] could possibly become unscrewed. Subsequently screw out the screw/screw-in tool.



Fig. 12

Machine Ensats® - installation...

Machine driving process

1. Precisely position the workpiece so that the bore and machine spindle are at right angles to each other (do not tilt).
Set the machine to the precise installation depth (appr. 0.1 to 0.2 mm below the surface of the workpiece see page 5).
2. Actuate the operating lever of the machine.
The rotatable outer shell of the tool must be resting against the outer visible stop pins at the beginning of the turning process so that it is driven by the pins in the clockwise direction.
3. Feed the Ensats® towards the tool (slot or cutting hole facing downwards) and grip for the duration of 2 to 4 revolutions.
4. Continue to actuate the operating lever of the machine and to guide the tool to the hole until the Ensats® cuts into the borehole. The remainder of the driving process takes place without actuating the feed.
5. Switch on the reversing function (depending on the type and structure of the device, this takes place automatically by means of a limit switch / depth sensor). Avoid setting the tool down hard on the workpiece as this can lead to breakage of both the tool and the Ensats®. It can also damage the play-free fit of the Ensats® and so reduce the pull-out strength. If necessary, adapt the driving speed in line with the necessary reversal time.

Machine installation takes place using the driving tools illustrated on page 7, mounted in:

1. Thread tapping machine

2. Drill press

with reversing system by means of depth stop or thread cutting head. Without guide cartridge, without feed.
Important: Do not exceed tightening torques.

3. Manual machine

With depth sensor and reversing system. See fig. 12.

4. Single or multiple installation machines

With pneumatic or electric drive; semi or fully automatic, computer controlled (CNC).
Note different pitches.

Guideline speed values for light alloy:

Ensats® female thread	Speed rpm [min ⁻¹]
M 2,5 / M 3	650 – 900
M 4 / M 5	400 – 600
M 6 / M 8	280 – 400
M 10 / M 12	200 – 300
M 14 / M 16	150 – 200
M 18 / M 20	120 – 200
M 22 / M 24	100 – 160
M 27 / M 30	80 – 140

Fig. 13

Guideline values for driving torques:

Ensats® M 2,5	1,5 Nm
Ensats® M 3	2,5 Nm
Ensats® M 4	5,5 Nm
Ensats® M 5	10 Nm
Ensats® M 6	15 Nm
Ensats® M 8	28 Nm
Ensats® M 10	40 Nm
Ensats® M 12	60 Nm
Ensats® M 14	100 Nm
Ensats® M 16	160 Nm
Ensats® M 18	220 Nm
Ensats® M 20	310 Nm
Ensats® M 22	420 Nm
Ensats® M 24	530 Nm
Ensats® M 27	770 Nm
Ensats® M 30	1050 Nm

Fig. 14

Torque M_D

The maximum admissible torque is dependent on:

1. The axial load capacity of the tool stud
2. The pressure resistance capacity of the Ensats® in the axial direction

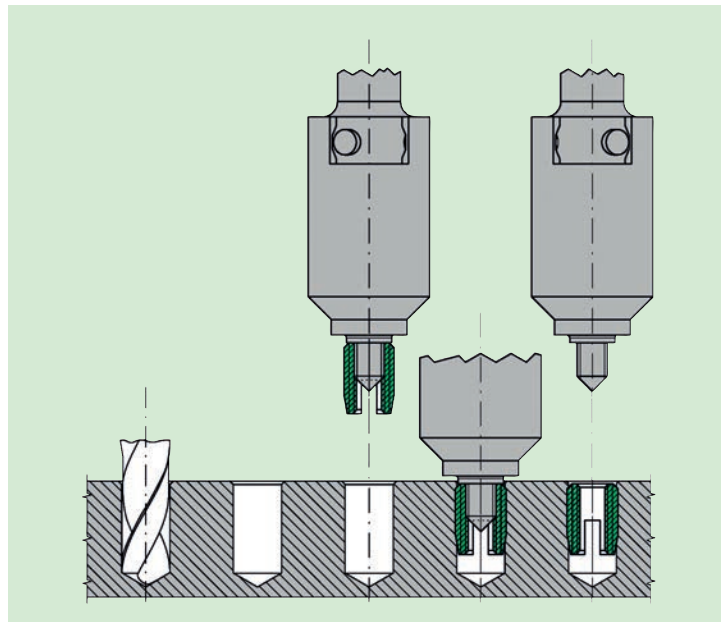

Fig. 15