

# Clifa® installation ...

## Installation

The receiving hole is punched, lasered or drilled **but not deburred or countersunk**.

With punched holes, Clifa® is pressed in from the punching burr side. The press-in process takes place on a plane parallel basis using a customary press with adjustable pressure level, until the surface of the shoulder in the Clifa® pressin nut comes to rest flat against the surface of the sheet metal.

In the case of the Clifa®-SP/SPD/SPS stud, the head must be fully pressed in and come to rest flush with the surface of the sheet metal.

Pressure which is too high or applied only on one side as well as inclined support surfaces must be avoided wherever possible.

## Examples for mounting

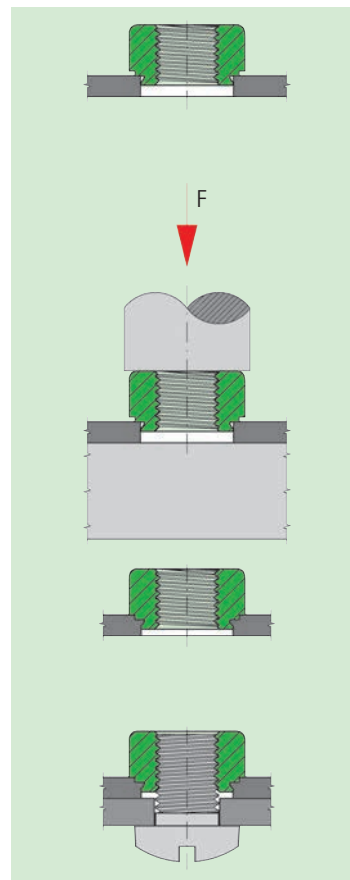

Press-in nut Clifa®

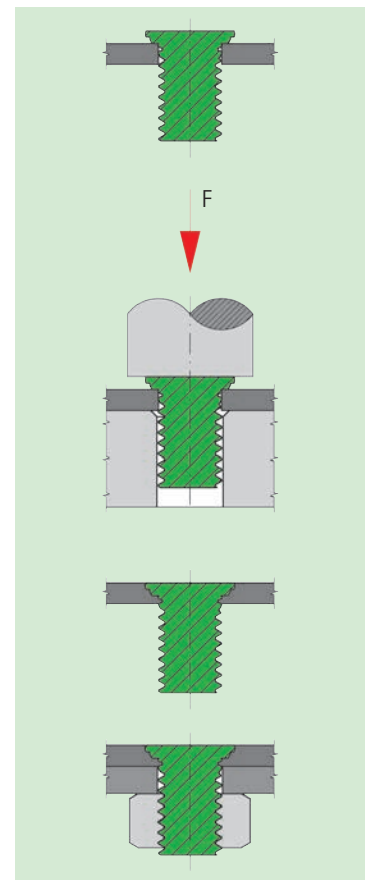

Press-in stud Clifa®-SP

Fig. 8

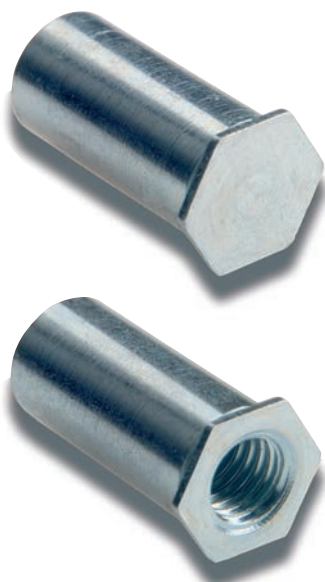

## Special request

short length
standoff bushings for metals
standoff bushings for plastics
threaded press-in stud
Flush surface on the press-in side of the nut element ( /- thread closed on one side)
Grub screw for thin sheet thicknesses
Grub screw for high load values
threaded press-in stud for lower press-in force

## We recommend

Clifa®-M	(Works Standard 500 0 to 503 0)
Clifa®-AM	(Works Standard 503 8 to 525 8)
Clifa®-AL	(Works Standard 503 6 to 525 6)
Clifa®-ABO/-ABG	(Works Standard 570 0 to 571 0)
Clifa®-SPD	(Works Standard 5.. 2)
Clifa®-SA	(Works Standard 515 4 to 534 4)
Clifa®-SAD	(Works Standard 515 9 to 534 9)



**Press-in stud**  
Press-fit geometrie flush fit processed

**Clifa®-SP**  
Works Standard  
506 0 to 534 0

**Application**

Clifa®-SP press-in grub screws are processed flush with the surface – see diagram –, and are used to manufacture wear-resistant, highly resilient screw connections in thin-walled moulded parts made of:

- Steel
- Stainless steel
- Brass
- Copper
- Light metal, etc.

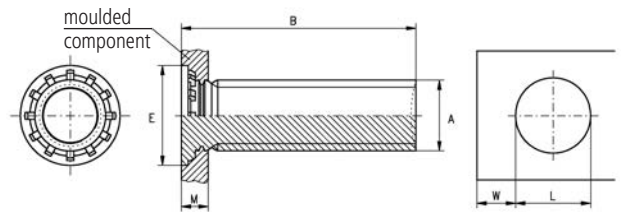

Dimensions in mm

Article number	Internal thread	Workpiece thickness	External diameter	Hole diameter	Minimum spacing	Tightening torque of the nut (guideline values for sheet metal) ≤ Nm
	A	≥ M	E	L +0,05	≥ W	
5.. 000 025 ...	M 2,5	1,0	4,0	2,5	3,5	0,7
5.. 000 030 ...	M 3	1,0	4,6	3,0	4,0	1,5
5.. 000 040 ...	M 4	1,0	5,9	4,0	5,0	2,9
5.. 000 050 ...	M 5	1,0	6,5	5,0	5,0	6,0
5.. 000 060 ...	M 6	1,5	8,5	6,0	5,0	10,0
5.. 000 080 ...	M 8	1,5	10,0	8,0	6,0	20,0

Article number first group of digits (selection series)	Length B*) ±0,2	Available					
		M 2,5	M 3	M 4	M 5	M 6	M 8
506 000 ... ..	6,0	X	X	X	X		
508 000 ... ..	8,0	X	X	X	X	X	
510 000 ... ..	10,0	X	X	X	X	X	X
515 000 ... ..	15,0	X	X	X	X	X	X
520 000 ... ..	20,0	X	X	X	X	X	X
525 000 ... ..	25,0	X	X	X	X	X	X
530 000 ... ..	30,0			X	X	X	X
534 000 ... ..	34,0			X	X	X	X

**Example for finding the article number**

Press-in stud Clifa®-SP, M3 tempered, zinc plated and blue passivated steel, 10 mm long, with serrations at the head for sheet metal thickness 1,2 mm: Clifa®-SP 510 000 030.110

**Materials**

Steel tempered, zinc plated, blue passivated \*\*

Steel tempered, zinc-nickel plated, transparent passivated \*\*

Stainless steel

Article no. (fourth group of digits) ... .. 110

Article no. (fourth group of digits) ... .. 143

Article no. (fourth group of digits) ... .. 500

**Further dimensions on request.**

**Threaded ends**

**Press-in grub screws with differing threaded ends on request, see data sheet, page 25.**

**Tolerances**

ISO 2768-m

**Thread**

Stud thread A: as per ISO 6g, imperial thread available in all customary sizes.

**Press-in force**

**Guideline values for press-in force, see page 24**

\*) Length B

available up to 60 mm

\*\*)

Press-in stud in tempered steel, available in customary strength classes.

Dimensions in mm

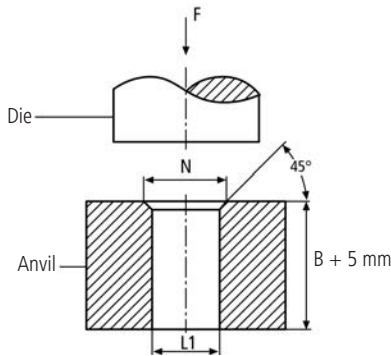

Anvil for: Clifa®	Hole L1 +0,1	Countersink for serrations N +0,1	Press-in force kN
M 2,5	2,6	3,4	8,9 to 12
M 3	3,1	4,0	10,5 to 19
M 4	4,1	5,2	16 to 25
M 5	5,1	6,4	29 to 35
M 6	6,1	7,6	30 to 50
M 8	8,1	10,2	30 to 60

The press-in force F is dependent on the Clifa® dimension, the material and the thickness of the shaped component and also the type of serration at the head. The Clifa® head must be fully embedded and must come to rest flush with the surface of the sheet metal. Excessive force must be avoided. The hole diameter of the part to be screwed on  $\approx A + 0,6$  mm.

Dimensions in mm

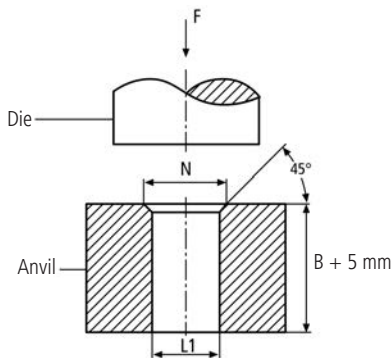

Anvil for: Clifa®	Hole L1 +0,1	Countersink for serrations N +0,1	Press-in force kN
Ø 5,0	5,1	6,4	29 to 35

The press-in force F is dependent on the Clifa® dimension, the material and the thickness of the shaped component and also the type of serration at the head. The Clifa® head must be fully embedded and must come to rest flush with the surface of the sheet metal. Excessive force must be avoided. The hole diameter of the part to be screwed on  $\approx A + 0,6$  mm.

Dimensions in mm

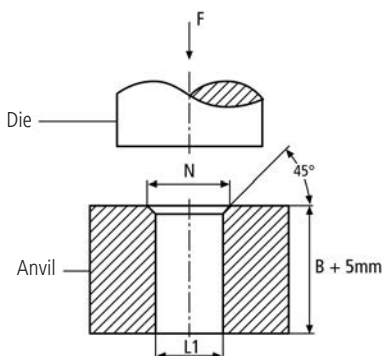

Anvil for: Clifa®	Hole L1 +0,1	Countersink for serrations N +0,1	Press-in force kN
M 3	3,1	4,0	9,0 to 15,0
M 4	4,1	5,2	14,5 to 38
M 5	5,1	6,4	21 to 42
M 6	6,1	7,6	21 to 50
M 8	8,1	10,2	21 to 60
M 10	10,1	12,2	32 to 84

The press-in force F is dependent on the Clifa® dimension, the material and the thickness of the shaped component and also the type of serration at the head. Excessive force must be avoided. The hole diameter of the part to be screwed on  $\approx A + 0,6$  mm.

**Application**

Depending on the demands placed on the Clifa® press-in grub screws, we offer a variety of threaded ends. Further threaded ends on request.

Sub-function	Type of threaded end			
	KKV	KK	PN	KK-MAG
Protection of start of thread	↘	↗	↗	↗
Larger displacement when fastening	↘	→	↗	↗
Prevention of tilting when fastening	↘	→	→	↗
Usable thread length (Version for components of the same length)	↗	→	→	↘

Type of threaded end: **KKV**  
DIN EN ISO 4753 (RL)

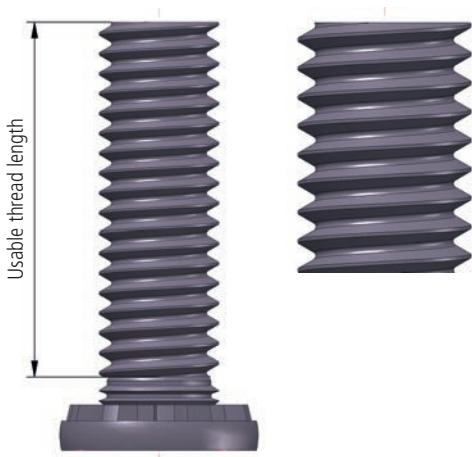

Type of threaded end: **KK**

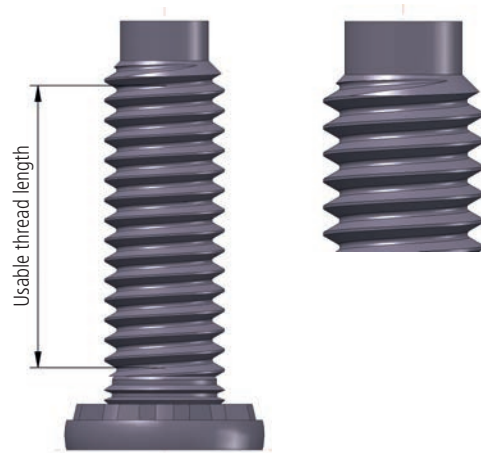

Type of threaded end: **PN**



Type of threaded end: **KK-MAG**

