

不锈钢蝶形铰链 加厚平型·锥孔型

code
5天发货

选型指南

标准	举例	型号
	Code	No.
		HY43S 65

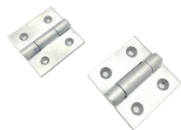

Code	材质	表面处理
HY43S	SUS304	镜面抛光
HY44S	SUS316	
HY43SA		

HY44S
No. =40 · 60

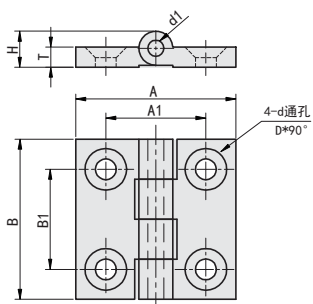

HY44S
No. =47 · 63 · 63A

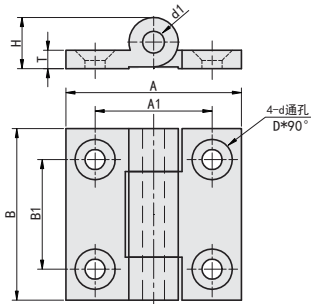

HY43S No. =50 · 65 · 75
HY44S No. =50 · 50A · 65 · 75

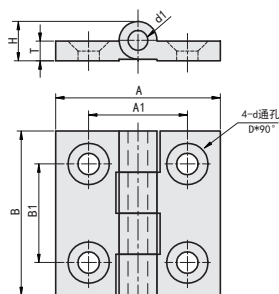

HY43S **HY44S**
No. =100

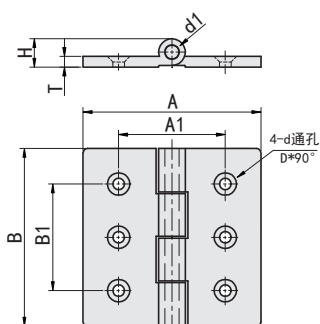

HY43SA
No. =50 · 65 · 75

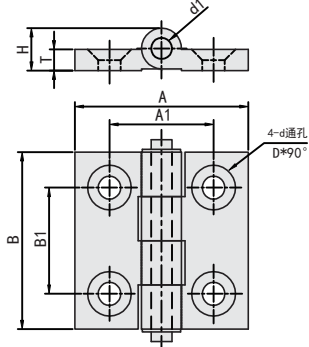

HY43SA
No. =100

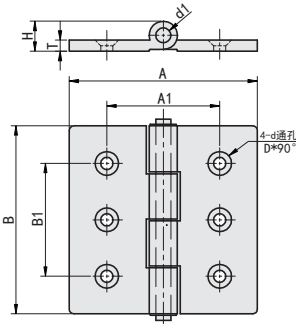

型号		A	B	A ₁	B ₁	H	T	D	d	d ₁	负载 (kg)	参考重量 (kg/pcs)
Code	No.											
HY44S	40	40	40	25	25	9	5	10.4	5.2	4	30	0.11
	47	48	47	32	30	14	5	11	5.5			0.12
	50	50	50	30	30	12	6	12.6	6.5	6	35	0.21
	50A			35	35							0.33
	60	60	60	36	36	15	8	16.3	8.3	8	40	0.59
	63	62	63	42	37	14	5	13		6	45	0.06
	63A	80	63	47	43	16	8			0.11		
	65	65	65	40	35	14		6	12.6	6	65	0.10
	75	75	75	50	40	15	7			65	0.19	
	100	100	100	60	60	16	8			85	0.19	
HY43S	50	50	50	30	30	12		6.5	6	35	0.12	
HY43S	65	65	65	40	35	14	6		45	0.21		
HY43SA	75	75	75	50	40	15	7		65	0.29		
HY43SA	100	100	100	60	60	16		8	85	0.52		

框架部品及配件

支柱

支柱座

支柱
固定夹

触摸屏
支架

支脚

脚轮

拉手

手柄·
旋钮

手轮

铰链

门部件