

Gasdruckfedern verminderte Bauhöhe

Gas springs reduced total height

Ressorts à gaz hauteur totale réduite

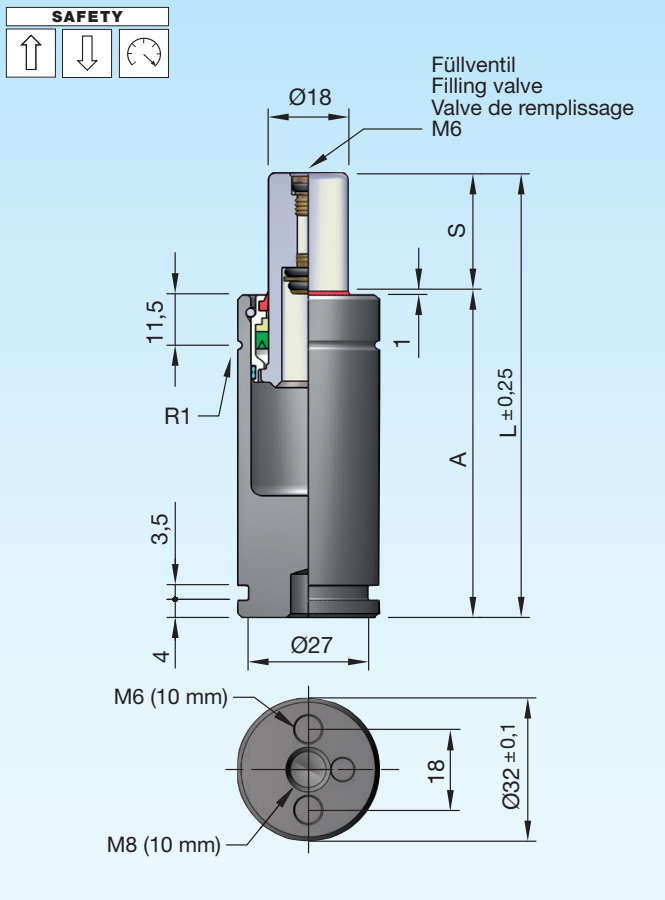

Einbauvarianten / Installation variants / Variantes de montage

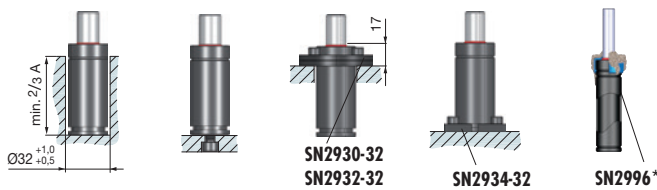

Druckmedium	Pressure medium	Médium de pression	Stickstoff (N₂)
Max. Fülldruck	Max. filling pressure	Pression de rempl. max.	150 bar
Min. Fülldruck	Min. filling pressure	Pression de rempl. min.	35 bar
Max. Betriebs-temperatur	Max. working temperature	Température de service max.	80 °C
Temperaturabhängige Druckerhöhung	Pressure increase due to temperature	Accroissement de pression sous l'influence de la temp.	0,33 %/1 °C
Instandhaltungsset	Maintenance kit	Jeu de maintenance	SN2990-C350
Max. Kolben-geschwindigkeit	Max. piston speed	Vitesse max. du piston	1,2 m/s

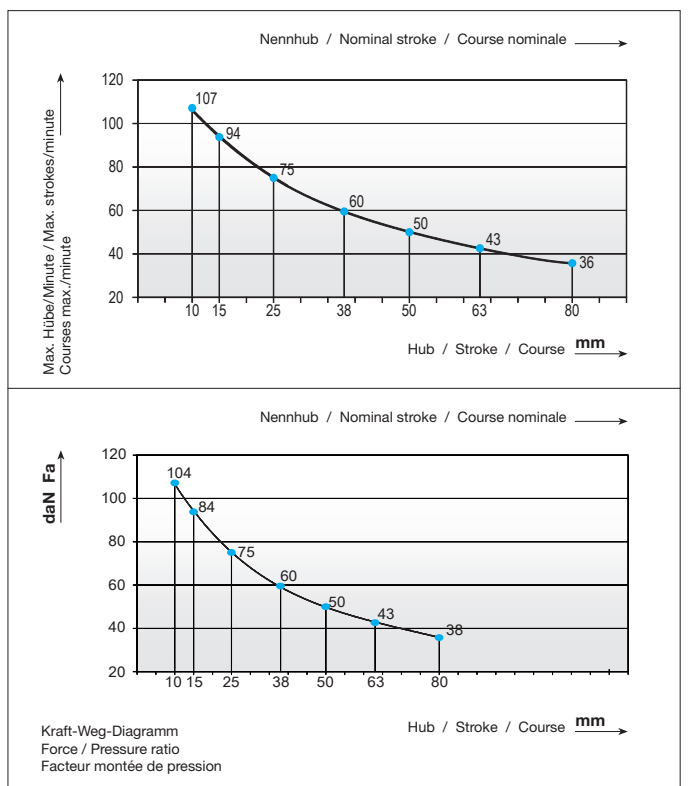

SN2830-350-



S = Hub / Stroke / Course

bar = Fülldruck / Filling pressure / Pression de remplissage

* i SN2996 = Seite / Page 2.3.254

S	daN	daN	bar	A	L	V [l]	Fa [cm ²]	kg
10	350	550	138	60	70	0,007	2,54	0,28
15	(±5%)	555	138	65	80	0,010	2,54	0,30
25		565	138	75	100	0,017	2,54	0,32
38		570	138	88	126	0,025	2,54	0,36
50		570	138	100	150	0,033	2,54	0,40
63		570	138	113	176	0,041	2,54	0,44
80		575	138	130	210	0,052	2,54	0,50