

Gasdruckfedern niedrige Bauhöhe

Gas springs low total height

Ressorts à gaz hauteur totale basse

3

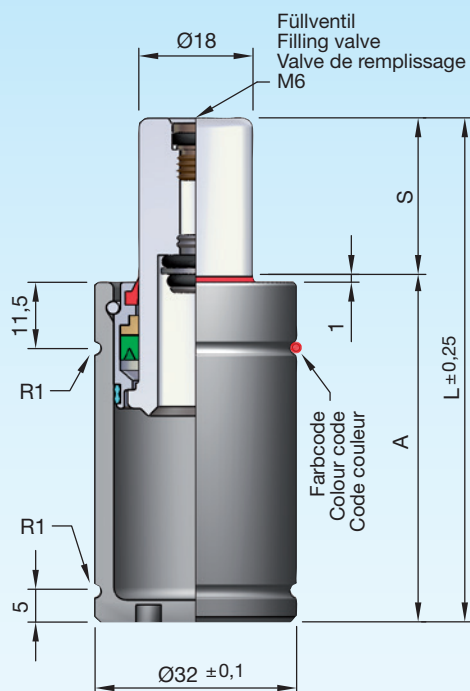

Einbauvarianten / Installation variants / Variantes de montage

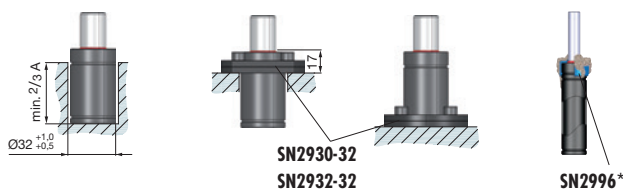

Druckmedium	Pressure medium	Médium de pression	Stickstoff (N₂)
Max. Fülldruck	Max. filling pressure	Pression de rempl. max.	155 bar
Min. Fülldruck	Min. filling pressure	Pression de rempl. min.	25 bar
Max. Betriebs- temperatur	Max. working temperature	Température de service max.	80 °C
Temperaturabhängige Druckerhöhung	Pressure increase due to temperature	Accroissement de pression sous l'influence de la temp.	0,33 %/1 °C
Instandhaltungsset	Maintenance kit	Jeu de maintenance	SN2990-K32
Max. Kolben- geschwindigkeit	Max. piston speed	Vitesse max. du piston	1,2 m/s

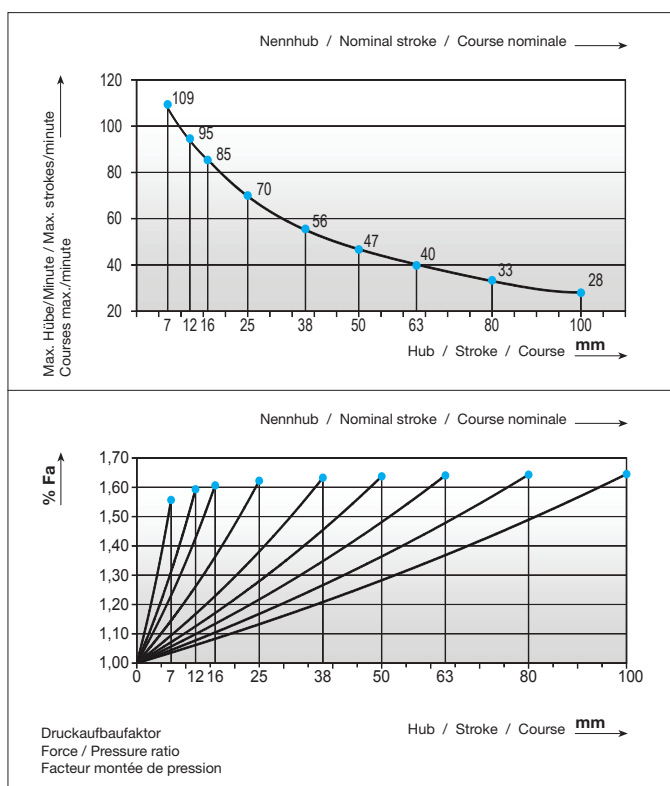

SN2809-400-		S	Type	A	L	V [l]	Fa [cm ²]	kg
	SN2809-400-S-Type	7	1	42	49	0,005	2,54	0,20
		12	2	47	59	0,008	2,54	0,21
		16	3	51	67	0,011	2,54	0,23
		25	4	60	85	0,017	2,54	0,26
		38		73	111	0,025	2,54	0,29
		50		85	135	0,033	2,54	0,33
		63		98	161	0,041	2,54	0,37
		80		115	195	0,052	2,54	0,43
		100		135	235	0,065	2,54	0,49
Type	Farbcodes Colour code Code couleur	daN	daN	bar				
1	Grün / Green / Vert	100 (+5)	165	40				
2	Blau / Blue / Bleu	200 (+10)	330	80				
3	Rot / Red / Rouge	300 (+15)	495	120				
4	Gelb / Yellow / Jaune	400 (+20)	640	155				
Andere Kräfte / Other forces / Autres forces		65- 400	≈100- 640	25- 155				

* i SN2996* = Seite / Page 2.3.254

D 3002A 07.2018