

Gasdruckfedern MICROserie - VDI 3003

Gas springs MICROseries - VDI 3003

Ressorts à gaz MICROsérie - VDI 3003

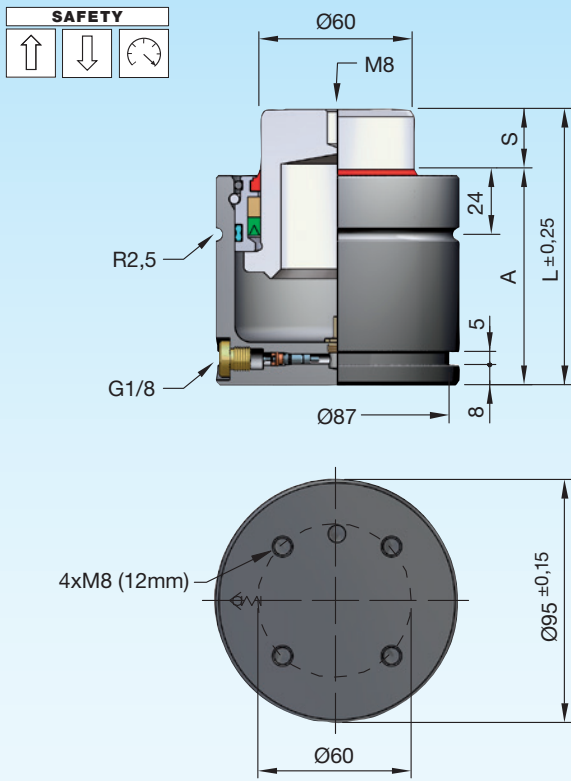

Druckmedium	Pressure medium	Médium de pression	Stickstoff (N ₂)
Max. Fülldruck	Max. filling pressure	Pression de rempl. max.	150 bar
Min. Fülldruck	Min. filling pressure	Pression de rempl. min.	35 bar
Max. Betriebs-temperatur	Max. working temperature	Température de service max.	80 °C
Temperaturabhängige Druckerhöhung	Pressure increase due to temperature	Accroissement de pression sous l'influence de la temp.	0,33 %/1 °C
Instandhaltungsset	Maintenance kit	Jeu de maintenance	SN2990-M95
Max. Kolben-geschwindigkeit	Max. piston speed	Vitesse max. du piston	1,6 m/s

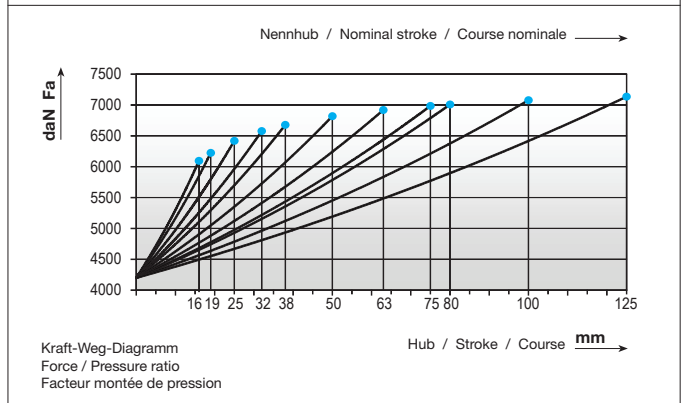
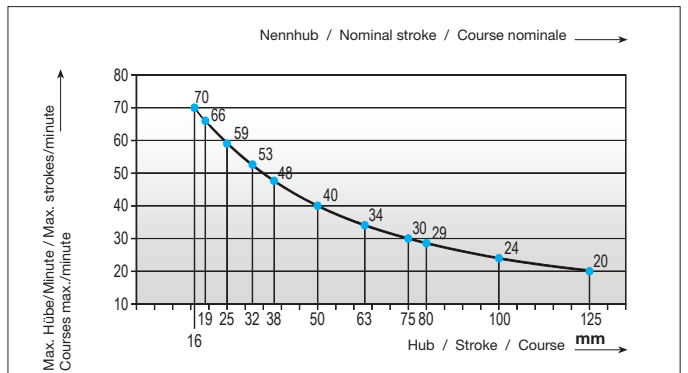

Einbauvarianten / Installation variants / Variantes de montage

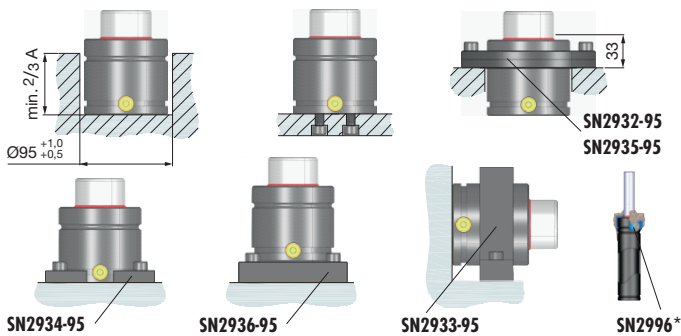

SN2808-4250-



SN2808-4250-S



S = Hub / Stroke / Course

bar = Fülldruck / Filling pressure / Pression de remplissage

* i SN2996 = Seite / Page 2.3.254

S	daN	daN	bar	A	L	V [l]	Fa [cm ²]	kg
16	4200	6155	150	74	90	0,146	28,27	2,80
19	(±5%)	6285	150	77	96	0,165	28,27	2,90
25		6485	150	83	108	0,204	28,27	3,10
32		6645	150	90	122	0,250	28,27	3,25
38		6745	150	96	134	0,290	28,27	3,70
50		6885	150	108	158	0,368	28,27	3,90
63		6990	150	121	184	0,453	28,27	4,40
75		7055	150	133	208	0,532	28,27	4,75
80		7075	150	138	218	0,565	28,27	4,90
100		7145	150	158	258	0,695	28,27	6,00
125		7205	150	183	308	0,859	28,27	6,50