

Gasdruckfedern MICROserie - VDI 3003

Gas springs MICROserie - VDI 3003

Ressorts à gaz MICROsérie - VDI 3003

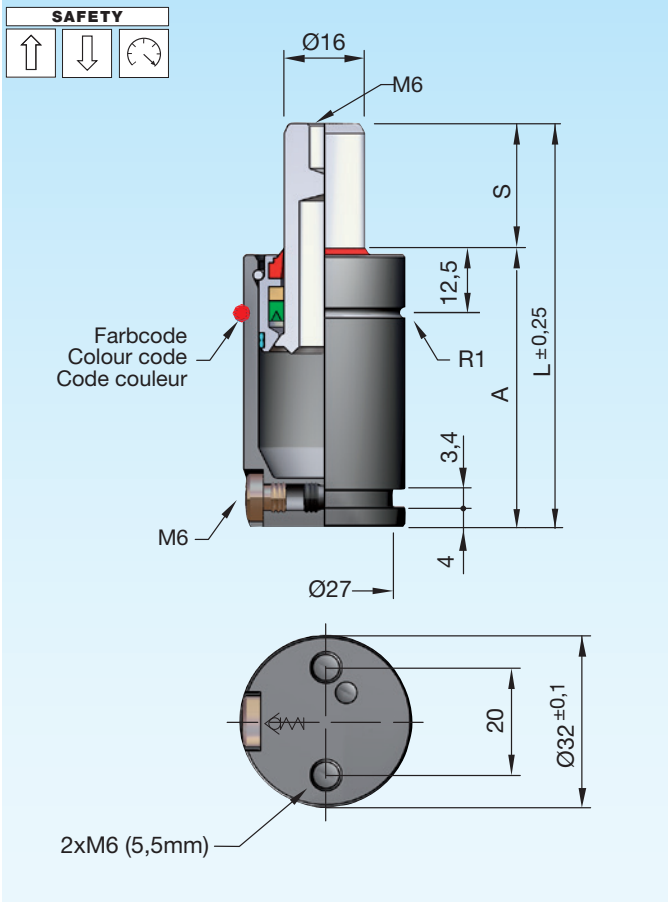

Druckmedium	Pressure medium	Médium de pression	Stickstoff (N₂)
Max. Fülldruck	Max. filling pressure	Pression de rempl. max.	175 bar
Min. Fülldruck	Min. filling pressure	Pression de rempl. min.	25 bar
Max. Betriebs-temperatur	Max. working temperature	Température de service max.	80 °C
Temperaturabhängige Druckerhöhung	Pressure increase due to temperature	Accroissement de pression sous l'influence de la temp.	0,33 %/1 °C
Instandhaltungsset	Maintenance kit	Jeu de maintenance	SN2990-MV32
Max. Kolben-geschwindigkeit	Max. piston speed	Vitesse max. du piston	1,6 m/s

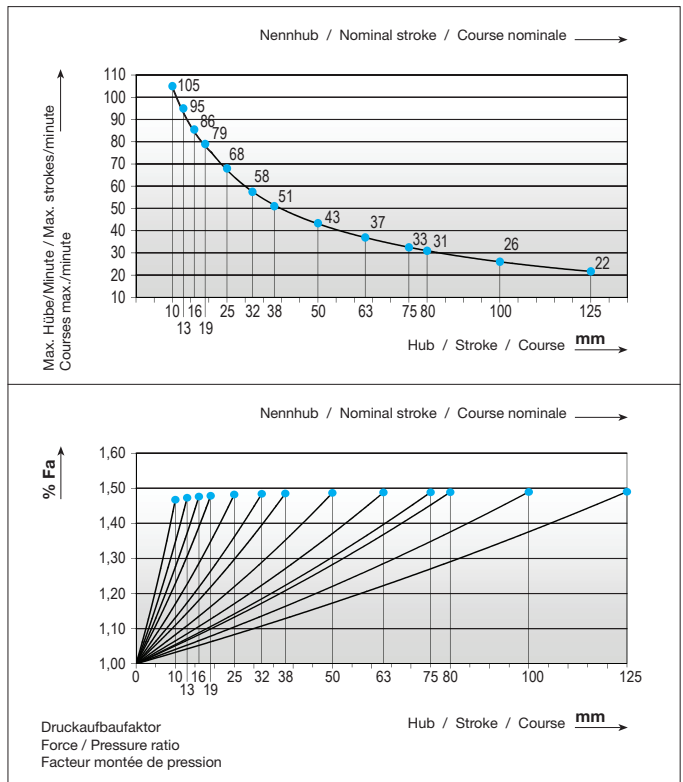

Einbauvarianten / Installation variants / Variantes de montage

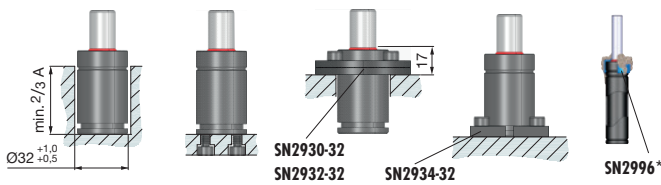

SN2808-VS-350-		VDI 3003			S	Type	A	L	V [l]	Fa [cm ²]	kg
SN2808-VS-350-S-Type		S = Hub / Stroke / Course bar = Fülldruck / Filling pressure / Pression de remplissage			10	1	40	50	0,007	2,01	0,16
					13	2	43	56	0,008	2,01	0,17
					16	3	46	62	0,010	2,01	0,18
					19	4	49	68	0,012	2,01	0,19
				25		55	80	0,016	2,01	0,20	
				32		62	94	0,020	2,01	0,22	
				38		68	106	0,024	2,01	0,24	
				50		80	130	0,031	2,01	0,28	
				63		93	156	0,039	2,01	0,33	
				75		105	180	0,046	2,01	0,36	
				80		110	190	0,049	2,01	0,38	
				100		130	230	0,061	2,01	0,44	
				125		155	280	0,076	2,01	0,51	
Andere Kräfte / Other forces / Autres forces		50-350	≈75-520	25-175							

i SN2996 = Seite / Page 2.3.254